

Internal Gear Pumps

Series QX

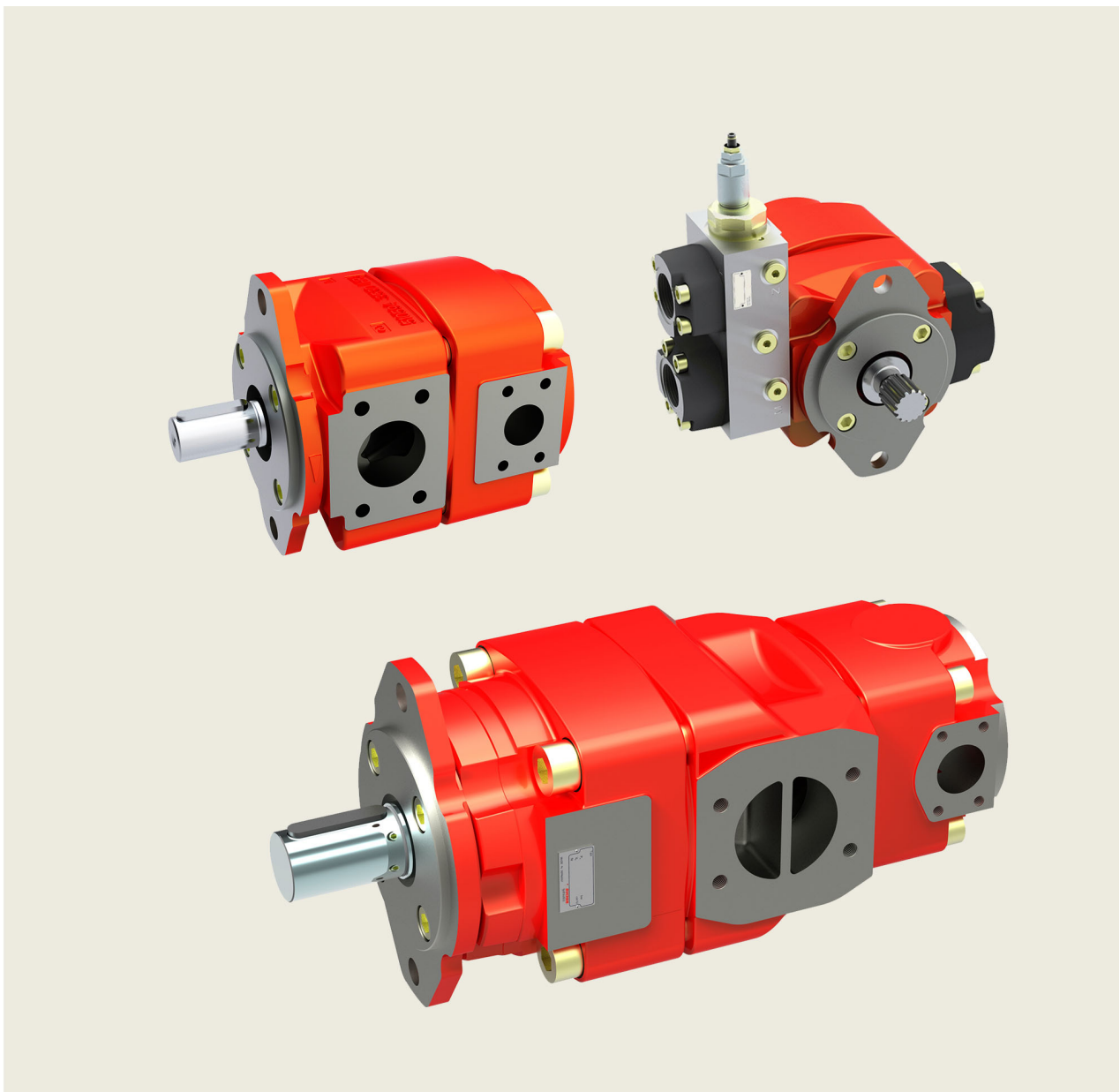

Contents		Page
1	General	5
	1.1 Product description	5
	1.2 Advantages	5
	1.3 ATEX compliant explosion protection	5
2	Technical data	5
	2.1 General (deviating values according manufacturer's specification)	5
	2.2 Main characteristics for pressure range 1	6
	2.3 Main characteristics for pressure range 2	7
	2.4 Main characteristics for pressure range 3	7
	2.5 Main characteristics for pressure range 4	8
	2.6 Calculation formula of the minimum speed	8
3	Performance graphs	9
	3.1 Noise level (Lp)	9
	3.2 Efficiency (η)	9
	3.3 Operation with variable-speed drives	11
4	Single pumps	12
	4.1 Dimensions frame size 2 - 4	12
	4.2 Dimensions frame size 5 - 8	13
	4.3 Pressure range 1	14
	4.4 Pressure range 2	14
	4.5 Pressure range 3	15
	4.6 Pressure range 4	15
	4.7 Pressure range 4 with low-flow capability	16
	4.8 Ordering code for single pumps	17
5	Double pumps	18
	5.1 Selection table	18
	5.2 Dimensions	19
	5.3 Ordering code for double pumps	28
6	Triple pumps	29
	6.1 Selection table	29
	6.2 Ordering code for triple pumps	30
7	Low-flow capability pump in combination with other QX-single pumps	31
	7.1 Dimensions	31
	7.2 Ordering code	32

8	Fluid	33
9	Fluid cleanliness class	33
10	Operational reliability	33
11	Note	33
12	Accessories	34
12.1	Bolt-on valves - SAE J518 code 61 / ISO 6162-1 pattern	34
12.2	Pipe flanges - high pressure type	35
12.3	Pipe flanges - low pressure type	36

1 General

1.1 Product description

The QX pumps are the 5th generation of Bucher internal gear pumps, which have proven themselves in thirty years of service around the world. Numerous improvements have been made to the straightforward and robust design.

Advances in the manufacturing process have made it possible without making higher demands on individual components to build pumps that are considerably lighter and more compact.

A new tooth profile, conceived and optimised with the help of CAE, has yielded another significant reduction in noise levels. Large sealing areas result in higher efficiencies.

The internal ring gear is supported by a hydrodynamic/hydrostatic lubrication film, which allows operation at low viscosities or low and high speeds. QX pumps are therefore suitable for use with variable speed drives, where they can provide variable flow rates.

1.3 ATEX compliant explosion protection

The internal gear pumps QX are suitable for application in hazardous areas and complies with the following guidelines:

ATEX directive	2014/34/EU
group	II
equipment category	3
atmosphere	G
temperature class	T3 and T4

1.2 Advantages

- Extremely long service life
- Volumetric efficiency up to 98%
- Suitable for use with variable speed drivers
- Can be used with fire resistant fluids (HFB, HFC and HFD = QXV), fuels, biodegradable and low-viscosity fluids
- Certifications by ATEX 2, ABS, DNV, GL, LR, NK, ...
- Low flow and pressure pulsations



II 3 G EEx c II T4
 -20°C ≤ Ta ≤ +40°C



II 3 G EEx c II T3
 -20°C ≤ Ta ≤ +80°C

2 Technical data

2.1 General (deviating values according manufacturer's specification)

General characteristics	Unit	Description, Value
Installation attitude		unrestricted
Mounting method (standard)		oval 2-hole flange to ISO 3019/1 (SAE): QX 3-6 oval 2-hole flange to ISO 3019/2 (metric): QX 2+8
Direction of rotation		CW or CCW
Pump drive method		in-line, through a flexible coupling
Volumetric efficiency η_v		up to 98%
Fluids		HLP mineral oils to DIN 51524 Part 2, HFC fluids to VDMA 24317
Maximum admissible level of contamination of the hydraulic fluid		ISO 4406 code 20/18/15 (see section 9)
Operating viscosity	mm ² /s	10 ... 100 *
Starting viscosity		10 ... 300 * *other values on request
Fluid temperature range	°C	HLP-mineral oils -20 min. / +80 max. / HFC +50 max. range for max. long life cycle +30 ... +60 (considering viscosity field)
Inlet pressure maximum minimum	bar	1.5 absolute (without external drain connection) 0.5 ... 0.98 absolute (dependent on pump frame size and speed, see example in section 3.3.2)
Startup against pressure	bar	max. 20 (other values on request)
Seal material		NBR = standard / FPM (Viton) = option 09

IMPORTANT: The main characteristics are valid for hydraulic oils DIN 51524 with a viscosity of 20 ... 50mm²/s.
The operating pressure at the pump outlet side is specified also for fire-resistant fluids (HFC).

2.2 Main characteristics for pressure range 1

Displacement effective ¹⁾ [cm ³ /rev]	Flow rate [l/min] 1450 min ⁻¹ p=0 bar	Maximum speed [rpm]	Minimum speed [rpm]	Code	Max. operating pressure at the pump outlet side				Torque ³⁾ [Nm]	Power consumption ⁴⁾ [kW]
					continuous [bar]		intermittent ²⁾ [bar]			
					Mineral oil	HFC	Mineral oil	HFC		
10,3	14,9	3600	1200	QX21-010	160	130	210	180	26	4,0
12,6	18,3			QX21-012	125	100	160	135	25	3,8
15,9	23,0			QX21-016	100	80	125	100	25	3,9
20,0	29,0	3000	900	QX31-020	160	130	210	180	51	7,7
25,2	36,7			QX31-025	125	100	160	135	50	7,7
31,1	45,2			QX31-032	100	80	125	100	50	7,5
40,6	59,0	3000	800	QX41-040	160	130	210	180	104	15,7
50,2	72,9			QX41-050	125	100	160	135	100	15,2
64,5	93,8			QX41-063	100	80	125	100	103	15,6
78,3	114,0	2300	800	QX51-080	160	130	210	180	200	30,4
100,6	146,0			QX51-100	125	100	160	135	201	30,5
126,7	184,0			QX51-125	100	80	125	100	203	30,8
159,7	232,0	1800 ⁶⁾	800	QX61-160	160	130	210	180	409	62,0
201,1	293,0			QX61-200	125	100	160	135	402	61,0
248,4	362,0			QX61-250	100	80	125	100	397	60,4
323,9	472,0	1750 ⁶⁾	800	QX81-315	160	130	210	180	830	126,0
400,1	583,0			QX81-400	125	100	160	135	801	121,6
495,4	722,0			QX81-500	100	80	125	100	793	120,5

1) Due to manufacturing tolerances, there may be slight variations in the displacement.

2) Max. 20 second and not more than 10% of the duty cycle.

3) Theoretical value at max. permitted continuous pressure for mineral oil.

4) Theoretical value at max. permitted continuous pressures for mineral oil at n = 1450 rpm.

5) For speeds > 1450 rpm, the inlet pressure of min. 0.95 bar absolute is required. For HFC application a second suction port is required.

6) Max. speed only possible with a second suction port, see section 2.2.1.

6) Min. speed only for 40 cSt. Example for calculation of the min. speed see chapter 2.6.

2.2.1 Suction arrangements for pump types QX61 and QX81

IMPORTANT: Minimum inlet pressure is 0.95 bar absolute with viscosity 10 ... 100 mm²/s (other values on request).

Type	Speed 1500 rpm suction height		Speed 1800 rpm suction height	
	up to 150 mm	over 150 mm	up to 150 mm	over 150 mm
QX61-160	I	I	I	II
QX61-200	I	I	I	II
QX61-250	I	II	II	II
QX81-315	I	II	II	II
QX81-400	II	II	II	-
QX81-500	II	II	-	-

I = standard pump with one suction port

II = model with two suction ports

All pump types coded II can be used without the second suction port up to 1200 rpm.

2.3 Main characteristics for pressure range 2

Displacement effective ¹⁾ [cm ³ /rev]	Flow rate [l/min] 1450 min ⁻¹ p=0 bar	Maximum speed [rpm]	Minimum speed [rpm]	Code	Max. operating pressure at the pump outlet side				Torque ³⁾ [Nm]	Power consumption ⁴⁾ [kW]
					continuous [bar]		intermittent ²⁾ [bar]			
					Mineral oil	HFC	Mineral oil	HFC		
5,1	7,4	3600	1500	QX22-005	210	180	250	210	17	2,6
6,3	9,1			QX22-006					21	3,2
7,9	11,5			QX22-008					27	4,0
10,0	14,5	3400	1400	QX32-010	210	180	250	210	34	5,1
12,6	18,3			QX32-012					42	6,4
15,6	22,6			QX32-016					52	7,9
20,3	29,5	3200	1200	QX42-020	210	180	250	210	68	10,4
25,1	36,4			QX42-025					84	12,7
32,3	46,8			QX42-032					108	16,5
39,1	56,9	2800	1000	QX52-040	210	180	250	210	132	19,9
50,3	73,2			QX52-050					170	25,7
63,4	92,1			QX52-063					213	32,3
79,8	116,0	2500 ⁵⁾	800	QX62-080	210	180	250	210	268	40,7
100,5	146,0	2300 ⁵⁾		338					51,2	
124,2	181,0	2000 ⁵⁾		417					63,4	
161,9	236,0	1800 ⁵⁾	800	QX82-160	210	180	250	210	544	82,7
200,0	291,0	1750 ⁵⁾		672					102,1	
247,7	361,0	1500 ⁵⁾		833					126,5	

2.4 Main characteristics for pressure range 3

Displacement effective ¹⁾ [cm ³ /rev]	Flow rate [l/min] 1450 min ⁻¹ p = 0 bar	Maximum speed [rpm]	Minimum speed [rpm]	Code	Max. operating pressure at the pump outlet side				Torque ³⁾ [Nm]	Power consumption ⁴⁾ [kW]
					continuous [bar]		intermittent ²⁾ [bar]			
					Mineral oil	HFC	Mineral oil	HFC		
5,1	7,4	3600	1400	QX23-005	320	280	400	350	26	4,0
6,3	9,1			QX23-006					32	4,9
7,9	11,5			QX23-008					41	6,2
10,0	14,5	3400	1100	QX33-010	320	280	400	350	51	7,7
12,6	18,3			QX33-012					64	9,7
15,6	22,6			QX33-016					80	12,1
20,3	29,5	3200	900	QX43-020	320	280	400	350	104	15,8
25,1	36,4			QX43-025					128	19,4
32,3	46,8			QX43-032					165	25,0
39,1	56,9	2800	800	QX53-040	320	280	400	350	200	30,4
50,3	73,2			QX53-050					258	39,1
63,4	92,1			QX53-063					321	49,3
79,8	116,0	2500 ⁵⁾	800	QX63-080	320	280	400	350	409	62,0
100,5	146,0	2300 ⁵⁾		514					78,1	
124,2	181,0	2000 ⁵⁾		636					96,5	
161,9	236,0	1800 ⁵⁾	800	QX83-160	320	280	400	350	830	126,0
200,0	291,0	1750 ⁵⁾		1025					155,7	
247,7	361,0	1500 ⁵⁾		1270					192,7	

1) Due to manufacturing tolerances, there may be slight variations in the displacement.

2) Max. 20 second and not more than 10% of the duty cycle.

3) Theoretical value at the max. permitted continuous pressure for mineral oil.

4) Theoretical value at the max. permitted continuous pressures for mineral oil at n = 1450 rpm.

5) For speeds > 1450 rpm, the inlet pressure of min. 0.95 bar absolute is required. For HFC application a second suction port is required.

6) Min. speed only for 40 cSt. Example for calculation of the min. speed see chapter 2.6.

2.5 Main characteristics for pressure range 4

Displacement effective ¹⁾ [cm ³ /rev]	Flow rate [l/min] 1450 min ⁻¹ p = 0 bar	Maximum speed [rpm]	Minimum speed ⁶⁾ [rpm]	Code	Max. operating pressure at the pump outlet side				Torque ³⁾ [Nm]	Power consumption [kW] ⁴⁾
					continuous [bar]		intermittent ²⁾ [bar]			
					Mineral oil	HFC	Mineral oil	HFC		
3,2 4,2	4,8 6,2	3600	1500	QX24-003 QX24-004	320	280	400	350	17 21	2,6 3,2
5,1 6,3 7,9	7,4 9,1 11,5	3600	1400	QX24-005 QX24-006 QX24-008	360	320	400	350	29 36 46	4,4 5,5 7,0
10,0 12,6 15,6	14,5 18,3 22,6	3600	1100	QX34-010 QX34-012 QX34-016	360	320	400	350	57 72 89	8,7 11,0 13,6
20,3 25,1 32,3	29,5 36,4 46,8	3600	900	QX44-020 QX44-025 QX44-032	360	320	400	350	117 144 186	17,7 21,8 28,2
39,1 50,3 63,4	56,9 73,2 92,1	3000	800	QX54-040 QX54-050 QX54-063	340	280	400	350	213 274 345	32,3 41,6 52,3
79,8 100,5 124,2	116,0 146,0 181,0	2500 ⁵⁾ 2300 ⁵⁾ 2000 ⁵⁾	800	QX64-080 QX64-100 QX64-125	330	280	400	350	421 530 655	64,0 80,5 99,5
161,9 200,0 247,7	236,0 291,0 361,0	1800 ⁵⁾ 1750 ⁵⁾ 1500 ⁵⁾	800	QX84-160 QX84-200 QX84-250	330	280	400	350	856 1057 1309	130,0 160,5 198,7

1) Due to manufacturing tolerances, there may be slight variations in the displacement.

2) Max. 20 second and not more than 10% of the duty cycle.

3) Theoretical value at the max. permitted continuous pressure for mineral oil.

4) Theoretical value at the max. permitted continuous pressures for mineral oil at n = 1450 rpm.

5) For speeds > 1450 rpm, the inlet pressure of min. 0.95 bar absolute is required.

6) Min. speed only for 40 cSt. Example for calculation of the min. speed see chapter 2.6.

2.6 Calculation formula of the minimum speed

$$n_{\min} = n_{\min \text{ at } 40 \text{ cSt}} \left[\frac{1}{\min} \right] \times \frac{\Delta p_{\text{operating pressure}} [\text{bar}]}{\Delta p_{\text{max. continuous}} [\text{bar}]} \times \frac{40 \text{ cSt}}{n_{\text{operating viscosity}} [\text{cSt}]}$$

Calculation of a QX44 with 250 bar and 30 cSt:

$$n_{\min} = 900 \frac{1}{\min} \times \frac{250 \text{ bar}}{360 \text{ bar}} \times \frac{40 \text{ cSt}}{30 \text{ cSt}} = 833 \frac{1}{\min}$$

3 Performance graphs

IMPORTANT: The performance graphs shown are valid for the specified pump models.
For other pump sizes, contact Bucher Hydraulics GmbH.

3.1 Noise level (L_p)

measured to DIN 45635, Part 26, in Stuttgart University's low-echo noise measurement chamber:
measurement distance 1 m
speed $n = 1500$ rpm
viscosity = $42 \text{ mm}^2/\text{s}$

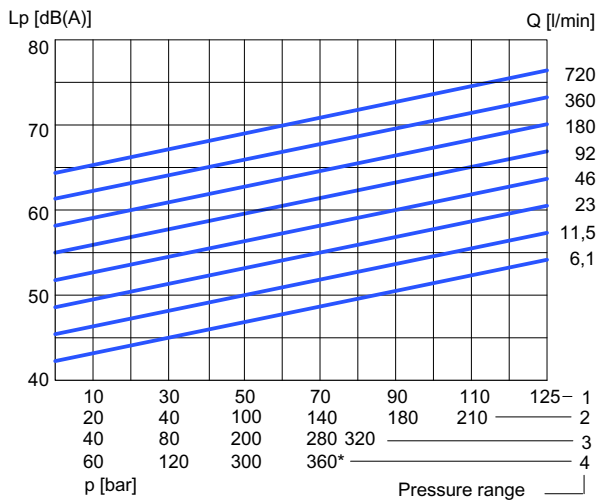

*Max. continuous operating pressure for pressure range 4 see section 2.5

3.2 Efficiency (η)

measured at speed 1450 rpm, viscosity $42 \text{ mm}^2/\text{s}$

3.2.1 Pressure range 1

3.2.1.1 Volumetric efficiency

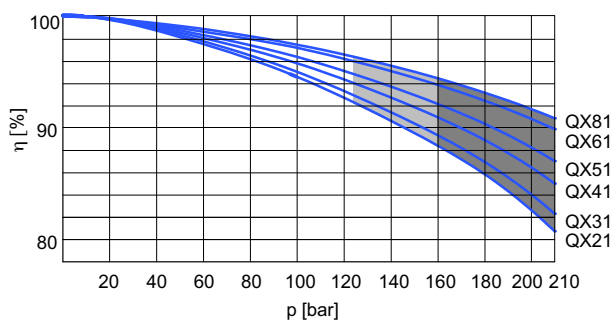

3.2.1.2 Hydromechanical efficiency

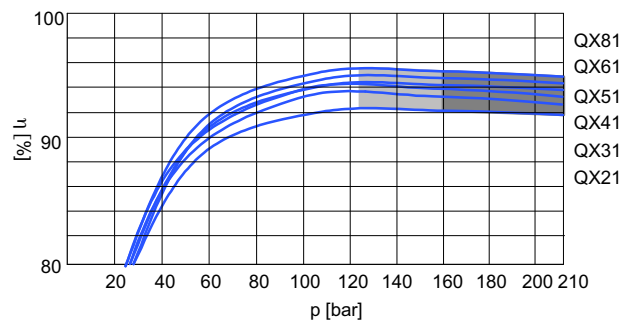

intermittent operating pressure as a function of displacement (see section 2.2)

3.2.2 Pressure range 2

3.2.2.1 Volumetric efficiency

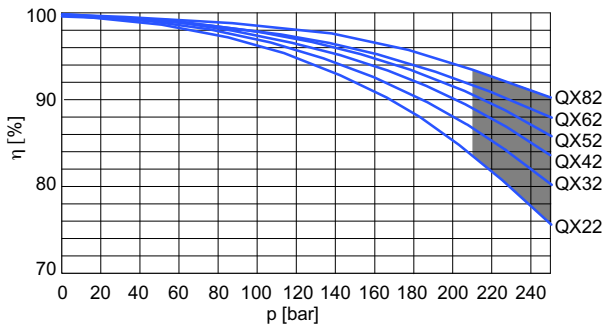

3.2.2.2 Hydromechanical efficiency

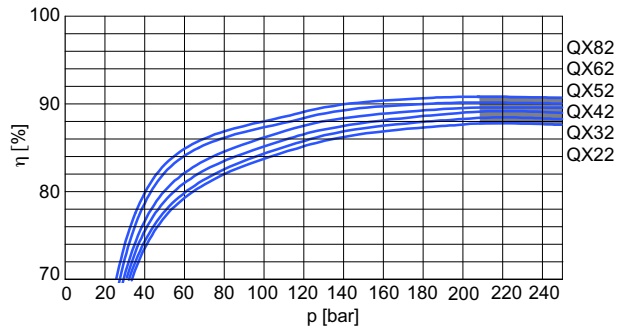

 intermittent operating pressure

3.2.3 Pressure range 3

3.2.3.1 Volumetric efficiency

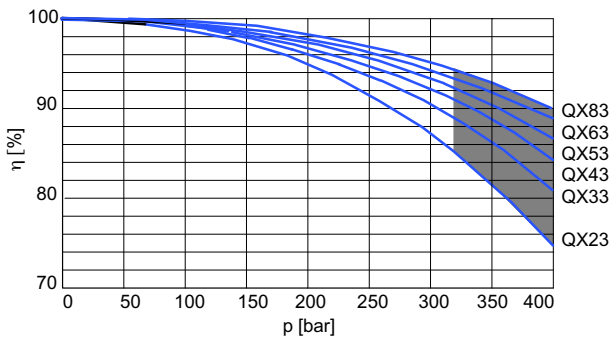

3.2.3.2 Hydromechanical efficiency

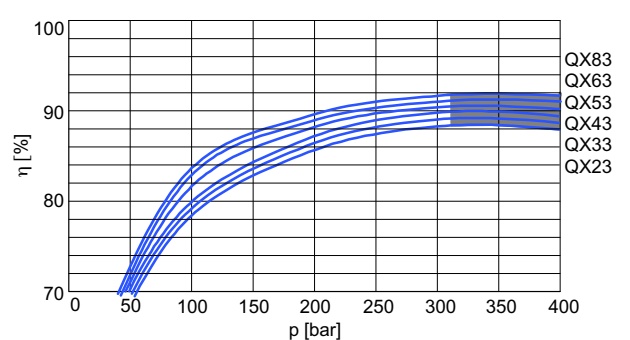

 intermittent operating pressure

3.2.4 Pressure range 4

3.2.4.1 Volumetric efficiency

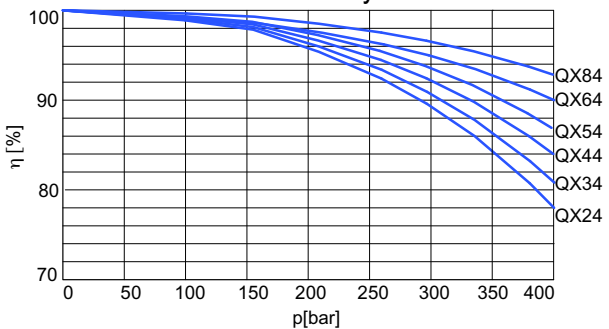

3.2.4.2 Hydromechanical efficiency

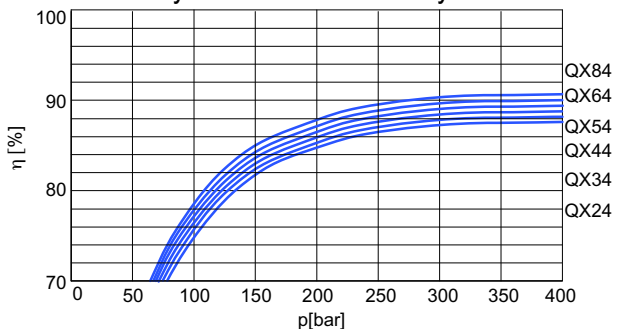

3.3 Operation with variable-speed drives

IMPORTANT: The following main characteristics are to be understood as examples only. They are valid only for the specified pump models and parameters. We would be very happy to advice you on the layout of your drive. QX pumps with variable-speed drive all contain an external drain port.

3.3.1 Typical loading cycle for a QX pump with variable-speed drive

Pump QX53-063 with viscosity 20 mm²/s

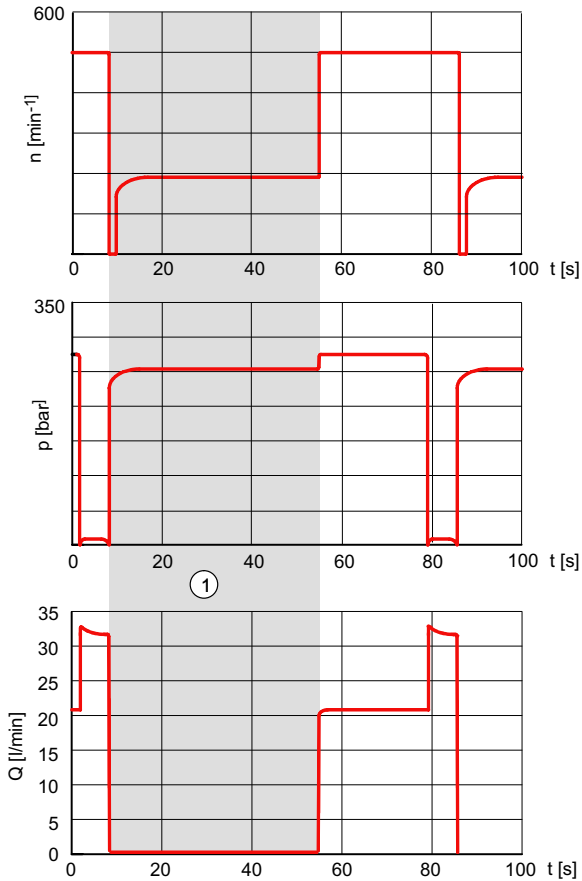

1 pressure-holding operation
 $Q = 0$ l/min for up to 60 s

3.3.2 Minimum pressure at suction port as a function of speed

Pump QX53-063 measured: with viscosity 42 mm²/s

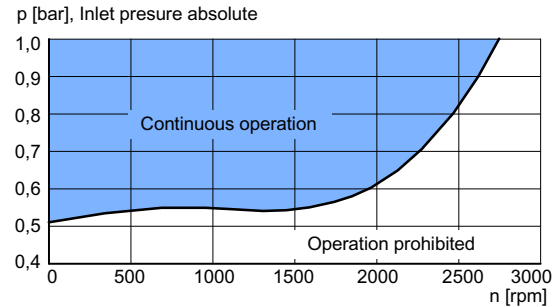

3.3.3 Minimum speed as a function of pressure

Pump QX53-063 measured with viscosity 42 mm²/s

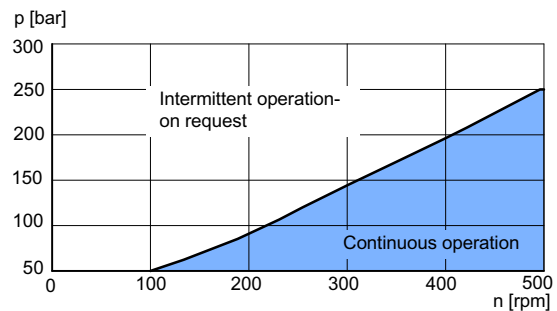

4 Single pumps

4.1 Dimensions frame size 2 - 4

Frame size		2				3				4			
Pressure range		1	2	3	4 ⁵⁾⁶⁾	1	2	3	4	1	2	3	4
Suction port: to SAE J518 ¹⁾	S	G1" thread ³⁾				G1¼" thread ³⁾				1½"			
Pressure port: to SAE J518 ¹⁾	P	G½" thread ³⁾ optional SAE J518 ⁴⁾				G¾" thread ³⁾ optional SAE J518 ⁴⁾				1"			
Mounting: oval 2-hole flange to ISO 3019/1 (SAE) ISO 3019/2 (metric)	A	118				132				170			
	B (SAE)	-				106				146			
	B (Metr.)	100				109				140			
	C	9				11				14			
	N (SAE)	-				82,55 _{-0,05}				101,6 _{-0,05}			
	N (Metr.)	63 h8				80 h8				100 h8			
	O	8,5				8,5				10,5			
	V	6				6				7			
4-hole flange ISO 3019/2	X (Metr.)	9				9				12			
	Y (Metr.)	85				103				125			
Shaft end: parallel, to ISO/R775 ²⁾	D	20 j6				25 j6				32 j6			
	E	36				42				58			
	F	6				8				10			
	G	22,5				28				35			
	I	45				50				68			
Housing	K	37,5				44				52,5			
	L	135	117	152	192	162	142,5	187,5	232,5	200	174	230	286
	M	-	55	90	125	-	69,5	114,5	159,5	-	87	143	199
	T1	43				55	53,5			67			
	T2	43				55	60			67	70		
	Z	100				120				125			
	W	80				100				136			
Weight	kg	6	6	7	8	10	10	13	15	20	18	22	27

1) Pipe flange dimensions, SAE J518 code 61 / ISO 6162-1.

High pressure type up to 420 bar (see section 12.2), low pressure type for up to 16 bar (see section 12.3).

2) For other shaft ends, contact Bucher Hydraulics GmbH.

3) Threaded ports to DIN 3852, Part 2.

4) Option 117: Pressure ports to SAE J518 code 61 / ISO 6162-1 can be supplied for pressure ranges 2 + 3 (see section 4.8.3).

5) The dimensions are not valid for low-flow capability pumps (3,3 cm³/U and 4,2 cm³/U, see chapter 4.7).

6) Internal gear pumps size 2 with low-flow capability (3,3 cm³/U and 4,2 cm³/U) are supplied with external drain port (option 06) as standard.

4.2 Dimensions frame size 5 - 8

Frame size		5				6				8			
Pressure range		1	2	3	4	1	2	3	4	1	2	3	4
Suction port: to SAE J518 ¹⁾	S	2"				2½"				3"			
Pressure port: to SAE J518 ¹⁾	P	1¼"				1½"				2"			
Mounting: oval 2-hole flange to ISO 3019/1 (SAE) ISO 3019/2 (metric) Mounting: oval 2-hole flange to ISO 3019/1 (SAE) ISO 3019/2 (metric)	A	212				267				330			
	B (SAE)	181				229				-			
	B (Metr.)	180				224				280			
	C	18				22				26			
	N (SAE)	127 _{-0,05}				152,4 _{-0,05}				-			
	N (Metr.)	125 h8				160 h8				200 h8			
	O	12,5				16,5				20			
	V	7				7				9			
4-hole flange ISO 3019/2	X (Metr.)	14				18				22			
	Y (Metr.)	160				200				250			
Shaft end: parallel, to ISO/R775 ²⁾	D	40 j6				50 j6				63 j6			
	E	82				82				105			
	F	12				14				18			
	G	43				53,5				67			
	I	92				92				117			
Housing	K	60,5				74				90			
	L	240,5	208,5	279,5	348,5	286	246	336	426	359	311	426	541
	M	-	102	172	242	-	119	209	299	-	151	266	381
	T1	90,5	89			107	110			137	138		
	T2	90,5	89			107	110			137	138		
	Z	156				195	197			250			
	W	165				203				256			
Weight	kg	36	32	41	50	64	57	77	90	130	118	160	200

1) Pipe flange dimensions, SAE J518 code 61 / ISO 6162-1.
 - high pressure type up to 420 bar (see section 12.2)
 - low pressure type for up to 16 bar (see section 12.3)

2) For other shaft ends, contact Bucher Hydraulics GmbH.

4.3 Pressure range 1

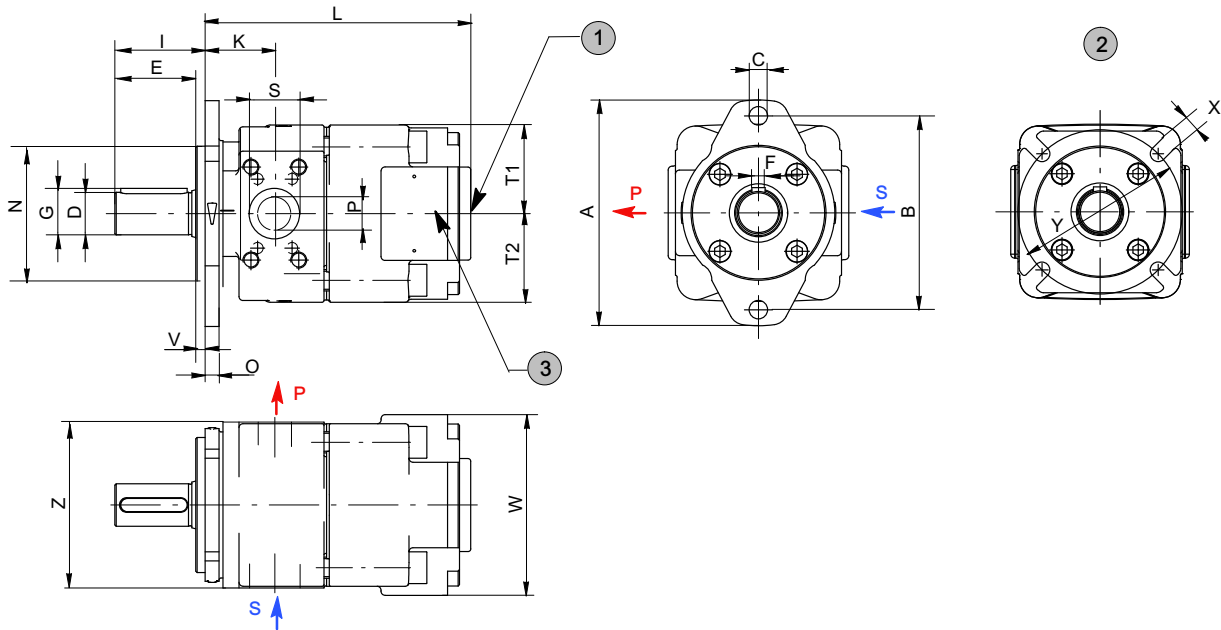

1	option 06 = external drain port
2	option 66 = special model 4-hole flange ISO 3019/2

3	option 83 = depending on operating conditions, a second suction port may be required on: QX51=SAE 1 1/4", QX61=SAE 2", QX81=SAE 2 1/2" - see section 2.2.1
---	--

4.4 Pressure range 2

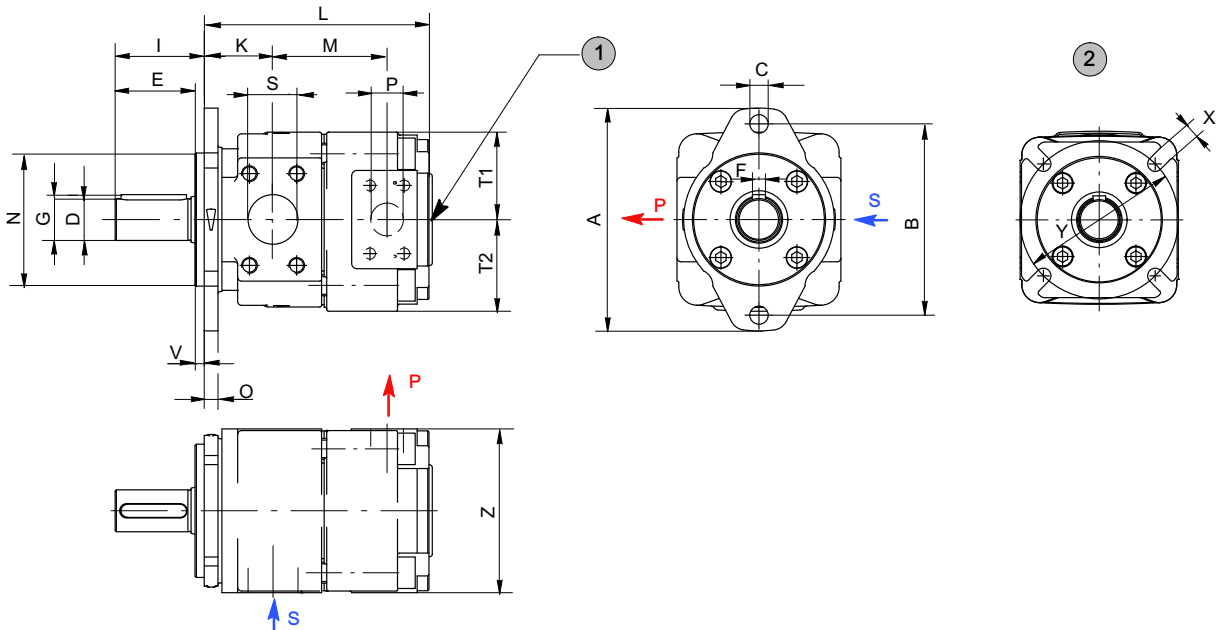

1	option 06 = external drain port
---	---------------------------------

2	option 66 = special model 4-hole flange ISO 3019/2
---	--

4.5 Pressure range 3

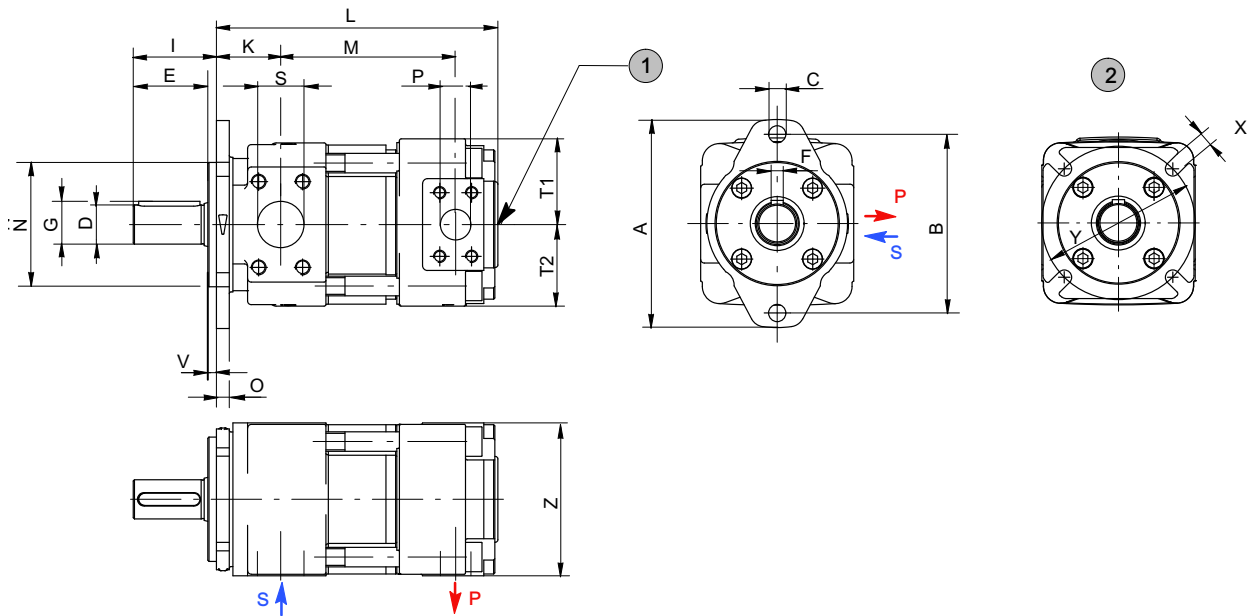

1 option 06 = external drain port

2 option 66 = special model 4-hole flange ISO 3019/2

4.6 Pressure range 4

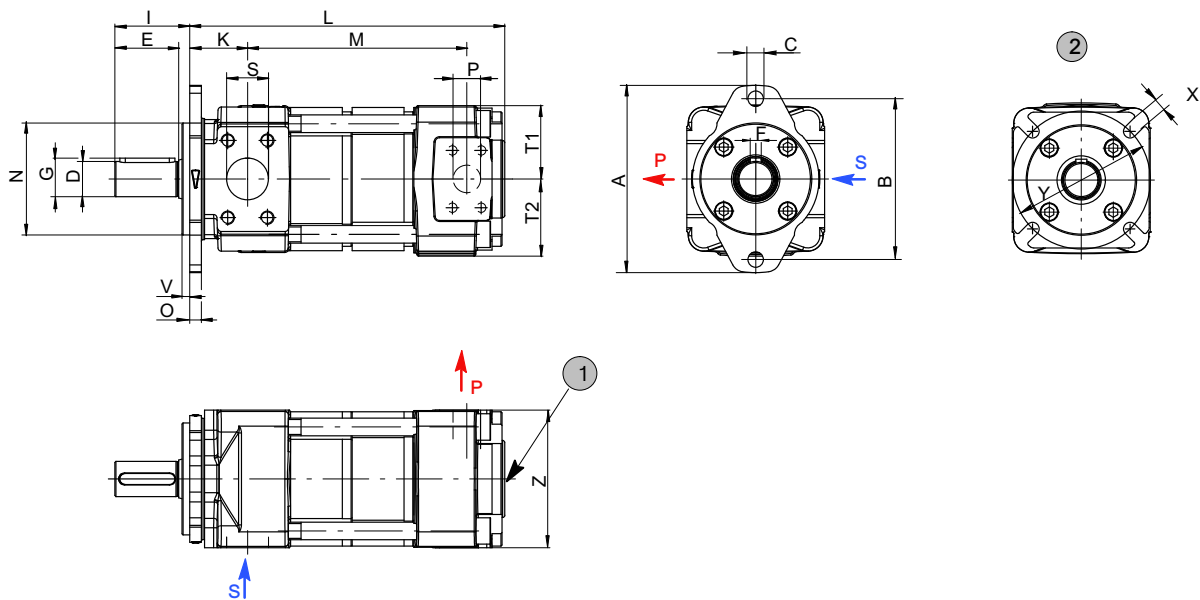

1 option 06 = external drain port

2 option 66 = special model 4-hole flange ISO 3019/2

4.7 Pressure range 4 with low-flow capability

QX24 with displacements from 3 and 4 cm³/U.

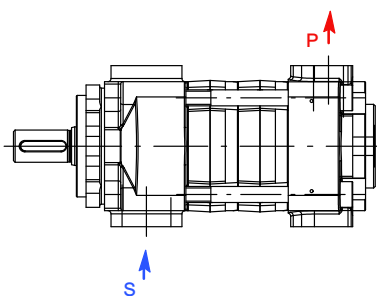
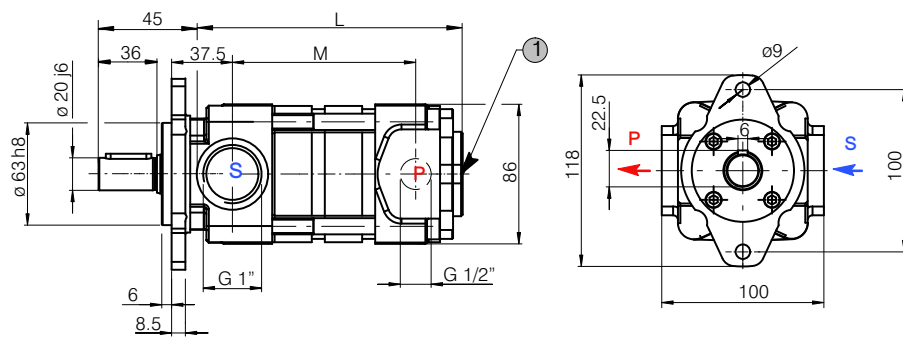

	L	M
3,3 & 4,2 cm ³ /U	179,5	113

1	Pump version only with option 06 (external drain port)
---	--

4.8 Ordering code for single pumps

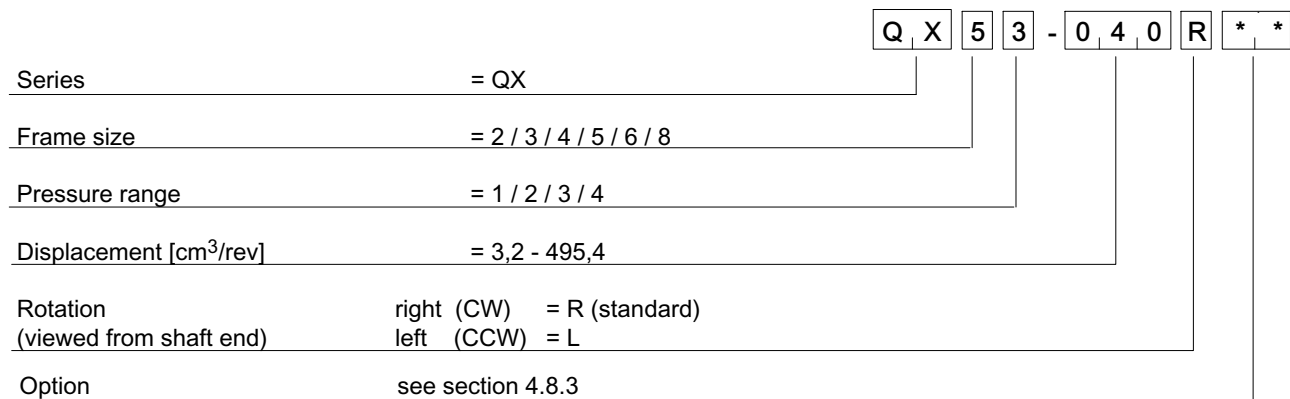

4.8.1 Ordering example:

Required: single pump
 Displacement: 40 cm³/rev
 Continuous pressure: 300 bar
 for use with mineral oil
 Ordering code: QX53-040R

4.8.2 Standard configuration

- direction of rotation - right (CW)
- 2-hole mounting flange to ISO 3019/1 (SAE): sizes QX 3-6
- 2-hole mounting flange to ISO 3019/2 (metric): sizes QX 2+8
- Nitrile seals
- cylindrical shaft end to ISO R775
- black priming, flange without priming

4.8.3 Option

- O = without priming
- 06 = external drain port in the pump rear cover
 - QX 2-5 = G¹/₄"
 - QX 6 = G³/₈"
 - QX 8 = G¹/₂"
- 09 = FPM (Viton) seals and without priming
- 12 = 2-hole mounting flange to ISO 3019/2 (metric): size QX 3-6
- 29 = for HFB and HFC fluids, frame sizes 2-5, without priming
- 66 = 4-hole mounting flange to ISO 3019/2 (metric)
- 83 = second suction port on:
 - QX51 = SAE 1¹/₄"
 - QX61 = SAE 2"
 - QX81 = SAE 2¹/₂"
- 117 = pressure port to SAE J518 code 61 / ISO 6162-1 can be supplied for frame size 2+3 with pressure ranges 2+3

Further options on request.

5 Double pumps

QX double pumps consist of two single pumps mounted on a common drive shaft. Hydraulically, the two pumps operate independently of one another but they share a common suction port in the pump's centre section. The larger pump of the combination is situated at the shaft end (the drive side) and is referred to as pump 1. With equal frame sizes, the pump with the larger displacement is situated at the drive side.

Double pumps can be combined as shown in the following table. If a letter is shown at the intersection point of the two pumps, the letter identifies the page in section 5.2 that contains the relevant dimensional drawing. If there is no letter at the intersection point, then that pump combination is not possible.

IMPORTANT: Double pumps with pressure range 4 on request.

5.1 Selection table

		Pump 2																	Maximum permissible torque [Nm] drive side		
		Displacement [cm ³ /rev]																			
		5/6/8		10/12/16		20/25/32		40/50/63		80/100/125		160/200/250		315	400	500					
		Maximum pressure [bar]																			
		250	400	125/160/210	250	400	125/160/210	250	400	125/160/210	250	400	125/160/210	250	400	125/160/210	250	400	125/160/210		
		QX22...	QX23...	QX21...	QX32...	QX33...	QX31...	QX42...	QX43...	QX41...	QX52...	QX53...	QX51...	QX62...	QX63...	QX61...	QX82...	QX83...	QX81...		
Pump 1	5/6/8	250	QX22..	E																65	
		400	QX23..	H	I																
	10/12/16	125/160/210	QX21..	B	C	A															130
		250	QX32..	E	F	D	E														
	20/25/32	400	QX33..	H	I	G	H	I													260
		125/160/210	QX31..	B	C	A	B	C	A												
	40/50/63	250	QX42..	E	F	D	E	F	D	E											520
		400	QX43..	H	I	G	H	I	G	H	I										
	80/100/125	125/160/210	QX41..	B	C	A	B	C	A	B	C	A									1050
		250	QX52..	E	F	D	E	F	D	E	F	D	E								
	160/200/250	400	QX53..	H	I	G	H	I	G	H	I	G	H	I							2100
		125/160/210	QX51..	B	C	A	B	C	A	B	C	A	B	C	A						
315/400/500	250	QX62..				E	F	D	E	F	D	E	F	D	E					2100	
	400	QX63..				H	I	G	H	I	G	H	I	G	H	I					
	125/160/210	QX61..				B	C	A	B	C	A	B	C	A	B	C	A			2100	
	250	QX82..							E	F	D	E	F	D	E	F	D	E			
	400	QX83..							H	I	G	H	I	G	H	I	G	H	I	2100	
	125/160/210	QX81..							B	C	A	B	C	A	B	C	A	B	C		

5.2 Dimensions

A Double pumps QX.1/1

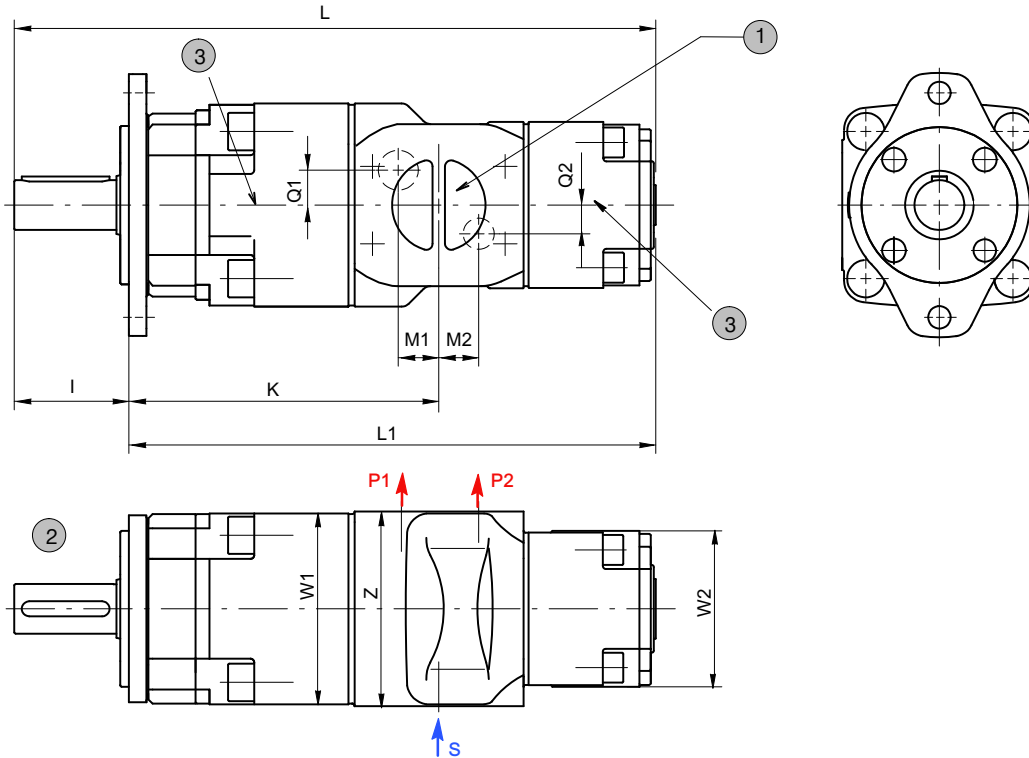

1	S = common suction port
2	shaft and mounting dimensions see section 4

3	option 83 = depending on operating conditions, a second suction port may be required - see section 2.2.1 QX51=SAE 1 1/4", QX61=SAE 2", QX81=SAE 2 1/2"
---	---

Type	L	L1	K	M1	M2	Q1	Q2	I	Z	W1	W2	S	P1	P2
QX21/21	294,5	249,5	140,5	18	18	-	-	45	100	80	80	G 1 1/4" 1)	G 1/2" 1) 2)	G 1/2" 1) 2)
QX31/21	342	292	170,5	26	30	-	-	50	120	100	80	G 1 1/2" 1)	G 3/4" 1) 2)	-
QX31/31	356	306								100	100			
QX41/21	394,9	326,5	200,5	20	35	15	15	68	125	136	80	SAE 2"	SAE 1"	G 1/2" 1) 2)
QX41/31	409	341			33					100	G 3/4" 1) 2)			
QX41/41	447	379	208	27,5	27,5	23	23	-	-	136	136	-	-	SAE 1"
QX51/21	466,5	374,5	241	22,5	42,5	15	-	92	156	165	80	SAE 2 1/2"	SAE 1 1/4"	G 1/2" 1) 2)
QX51/31	481	389			38,5					15	15			165
QX51/41	519	427	248,5	30	32	28	28	92	195	165	136	SAE 3"	SAE 1 1/2"	SAE 1"
QX51/51	545,5	453,5			30					28	165			165
QX61/31	539,5	447,5	287	24	47	17	14	92	195	203	100	SAE 3 1/2"	SAE 2"	G 3/4" 1) 2)
QX61/41	562,5	470,5		27	39	26	27			203	136			SAE 1"
QX61/51	599	507	292	32	40	35	35	117	250	203	165	SAE 3 1/2"	SAE 2"	SAE 1 1/4"
QX61/61	626	534			32					35	203			203
QX81/41	677	560	359	34,5	50,5	25	25	117	250	250	136	SAE 3 1/2"	SAE 2"	SAE 1"
QX81/51	703,5	586,5		35,5	46,5					30	35			250
QX81/61	730,5	613,5		37,5	44,5	40	40			250	203	SAE 1 1/2"		
QX81/81	772,5	655,5		37,5	37,5					256	256	SAE 2"		

1) Threaded port to DIN 3852 Part 2.

2) pressure port to SAE J518 code 61 / ISO 6162-1 can be supplied for pressure ranges 2+3.

B Double pumps QX.1/2

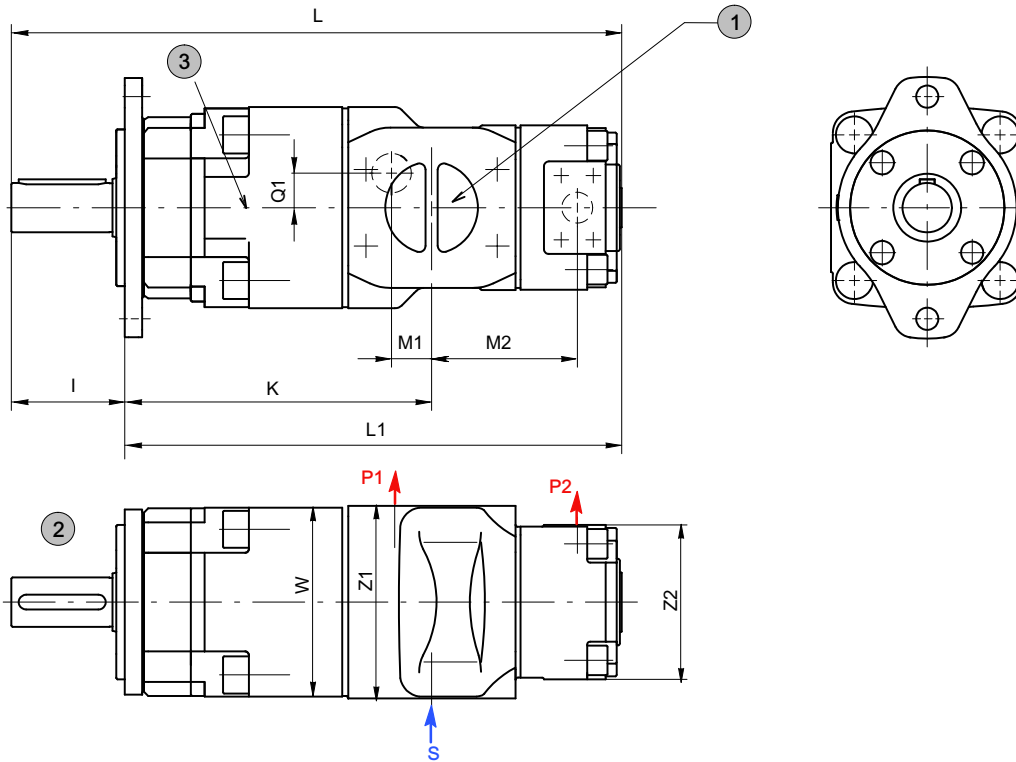

1	S = common suction port
2	shaft and mounting dimensions see section 4

3	option 83 = depending on operating conditions, a second suction port may be required - see section 2.2.1: QX51=SAE 1¼", QX61=SAE 2", QX81=SAE 2½"
---	---

Type	L	L1	K	M1	M2	Q1	I	Z1	Z2	W	S	P1	P2	
QX21/22	276,5	231,5	140,5	18	67	-	45	100	100	80	G1¼" 1)	G½" 1) 2)	G½" 1) 2)	
QX31/22	324	274	170,5	26	79		50	120	100	G1½" 1)	G¾" 1) 2)	G¾" 1) 2)		
QX31/32	336,5	286,5			87		120	100						
QX41/22	376,5	308,5	200,5	20	84	15	68	125	100	136	SAE 2"	SAE 1"	G½" 1) 2)	
QX41/32	389,5	321,5			92				120				G¾" 1) 2)	
QX41/42	421	353	208	26	110,5	23			125				SAE 1"	
QX51/22	448,5	356,5	241	22,5	91,5	15	92	156	100	165	SAE 2½"	SAE 1¼"	G½" 1) 2)	
QX51/32	462	370			99,5				120				G¾" 1) 2)	
QX51/42	493	401	248,5	30	118	28	92	156	125	203	SAE 3"	SAE 1½"	SAE 1"	
QX51/52	513,5	421,5			127				156				SAE 1¼"	
QX61/32	520	428	287	24	112	17	92	195	120	203	SAE 3"	SAE 1½"	G¾" 1) 2)	
QX61/42	536,5	444,5			27				123				26	125
QX61/52	567	475	292	32	137	35	92	195	156	203	SAE 3"	SAE 1½"	SAE 1¼"	
QX61/62	586	494			149				197				SAE 1½"	
QX81/42	651	534	359	34,5	140,5	25	117	250	125	256	SAE 3½"	SAE 2"	SAE 1"	
QX81/52	671	554			150				156				SAE 1¼"	
QX81/62	690,5	573,5		37,5	161,5	178,5	40	117	250	197	256	SAE 4"	SAE 2"	SAE 1½"
QX81/82	724,5	607,5								250				SAE 2"

1) Threaded port to DIN 3852, Part 2.

2) Pressure port to SAE J518 code 61 / ISO 6162-1 can be supplied for pressure ranges 2+3.

C Double pumps QX.1/3

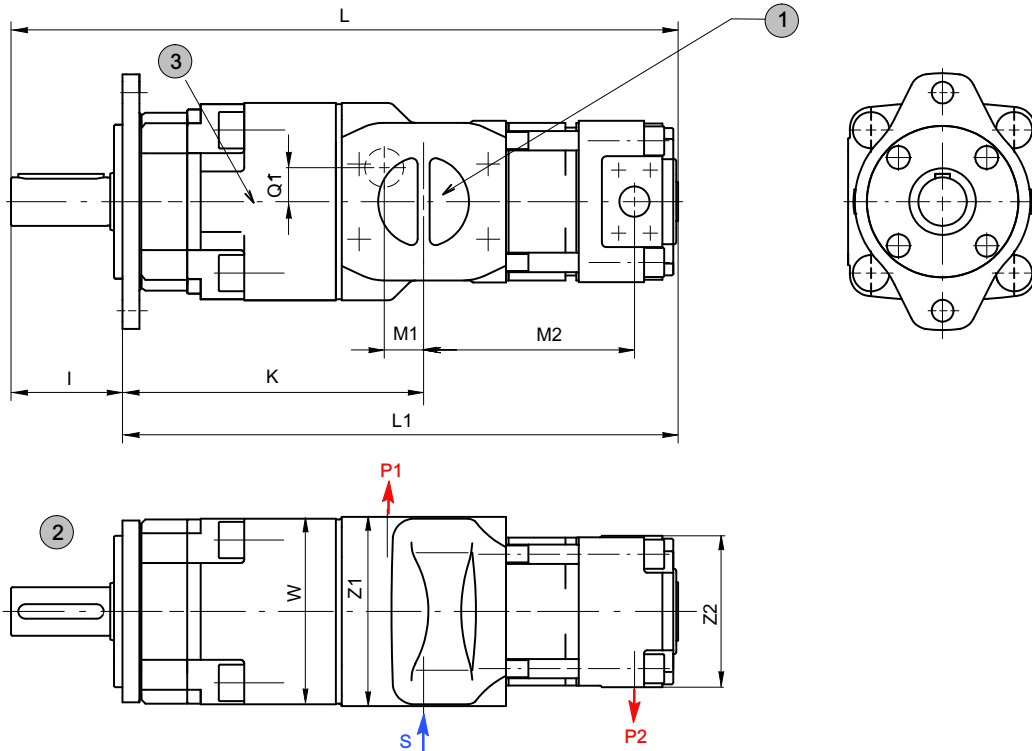

1	S = common suction port
2	shaft and mounting dimensions see section 4

3	option 83 = depending on operating conditions, a second suction port may be required - see section 2.2.1: QX51=SAE 1¼", QX61=SAE 2", QX81=SAE 2½"
---	---

Type	L	L1	K	M1	M2	Q1	I	Z1	Z2	W	S	P1	P2
QX21/23	311,5	266,5	140,5	18	102	-	45	100	100	80	G1¼" 1)	G ½" 1) 2)	G½" 1) 2)
QX31/23	358,5	308,5	170,5	26	114		50	120	120	100	G1½" 1)	G ¾" 1) 2)	
QX31/33	382	332			200,5	18,5	132	15	68	125	136	SAE 2"	SAE 1"
QX41/23	412	344	119	137			23						
QX41/33	434,5	366,5			248,5	30		174	28	197	156	203	SAE 2"
QX41/43	477	409	287	24			157						
QX51/23	484	392			241	22,5		126,5	15	92	156	165	SAE 2½"
QX51/33	506,5	414,5	248,5	30			144,5						
QX51/43	549	457			287	24		157	17	92	195	203	SAE 3"
QX51/53	583,5	491,5	292	27			179						
QX61/33	565	473			287	27		179	26	92	195	203	SAE 3"
QX61/43	592,5	500,5	292	32			207						
QX61/53	637	545			292	32		207	35	92	195	203	SAE 3"
QX61/63	676	584	359	32			239						
QX81/43	707	590			359	34,5		196,5	25	117	250	256	SAE 3½"
QX81/53	741,5	624,5	359	35,5			219,5						
QX81/63	780,5	663,5			359	37,5		251,5	40	117	250	256	SAE 4"
QX81/83	839,5	722,5	359	37,5			293,5						

1) Threaded port to DIN 3852, Part 2.

2) Pressure port to SAE J518 code 61 / ISO 6162-1 can be supplied for pressure ranges 2+3.

D Double pumps QX.2/1

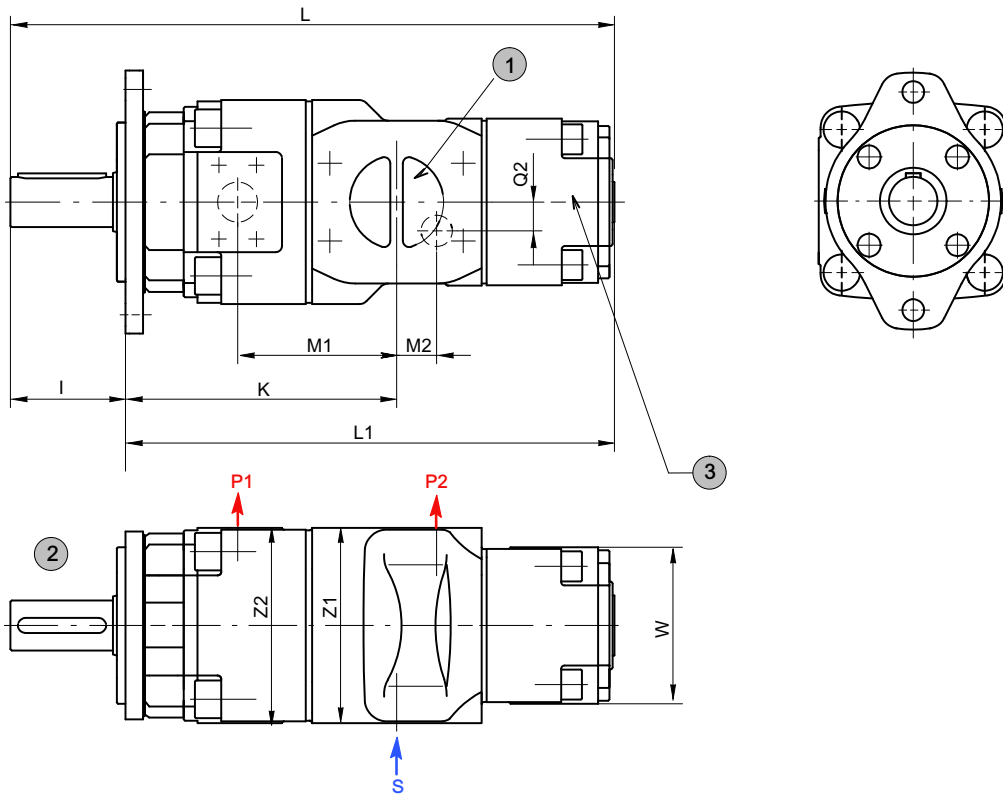

1	S = common suction port
2	shaft and mounting dimensions see section 4

3	option 83 = depending on operating conditions, a second suction port may be required - see section 2.2.1: QX51=SAE 1 1/4", QX61=SAE 2"
---	---

Type	L	L1	K	M1	M2	Q2	I	Z1	Z2	W	S	P1	P2
QX32/21	322	272	150,5	87	30	-	50	120	120	80	G1 1/2" ¹⁾	G3/4" ^{1) 2)}	G1 1/2" ^{1) 2)}
QX42/21	369	301	174,5	103	35	-	68	125	125		SAE 2"	SAE 1"	G3/4" ^{1) 2)}
QX42/31	383	315			33	15				SAE 2"	SAE 1"		
QX52/21	434,5	342,5	209	119,5	43	-	92	156	156	80	SAE 2 1/2"	SAE 1 1/4"	G1 1/2" ^{1) 2)}
QX52/31	449	357			38,5	15							G3/4" ^{1) 2)}
QX52/41	487	395	216,5	127	32	23	92	195	197	136	SAE 3"	SAE 1 1/2"	SAE 1"
QX62/31	499,5	407,5	247	144	47	14							100
QX62/41	522,5	430,5			39	27	136	SAE 1"					
QX62/51	559	467	252	149	40	28	117	250	250	165	SAE 3 1/2"	SAE 2"	SAE 1 1/4"
QX82/41	627	510	309	178,5	50,5	25							136
QX82/51	653,5	536,5			46,5	30	165	SAE 2"	SAE 1 1/4"				
QX82/61	680,5	563,5			44,5	35	203	SAE 4"	SAE 1 1/2"				

1) Threaded port to DIN 3852, Part 2.

2) Pressure port to SAE J518 code 61 / ISO 6162-1 can be supplied for pressure ranges 2+3.

E Double pumps QX.2/2

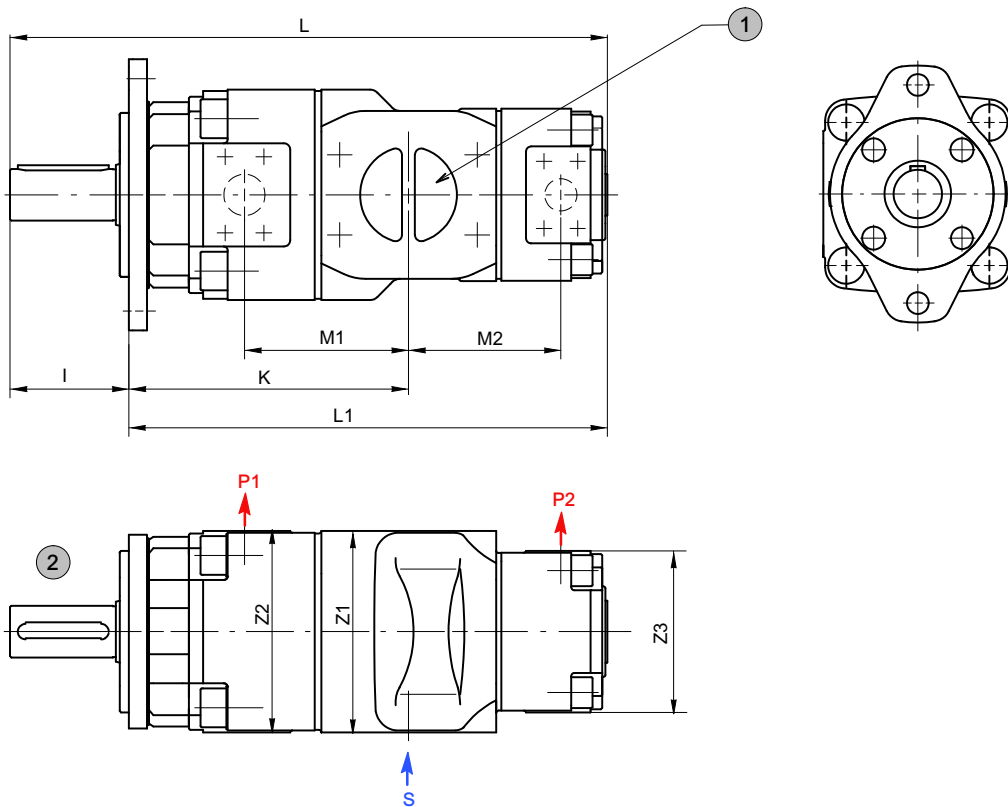

1 S = common suction port

2 shaft and mounting dimensions - see section 4

Type	L	L1	K	M1	M2	I	Z1	Z2	Z3	S	P1	P2
QX22/22	258,5	213,5	122,5	67	67	45	100		100	G1¼" 1)	G ½" 1) 2)	G½" 1) 2)
QX32/22	304	254	150,5	87	79	50	120		120	G1½" 1)	G ¾" 1) 2)	G¾" 1) 2)
QX32/32	317	267			87							
QX42/22	351	283	174,5	103	84	68	125		100	SAE 2"	SAE 1"	G½" 1) 2)
QX42/32	363,5	295,5			92			120	G¾" 1) 2)			
QX42/42	395	327			110,5			110,5	125			SAE 1"
QX52/22	416,5	324,5	209	119,5	91,5	92	156		100	SAE 2½"	SAE 1¼"	G½" 1) 2)
QX52/32	429,5	337,5			99,5			120	G¾" 1) 2)			
QX52/42	461	369	216,5	127	118	92	195	197	125	SAE 3"	SAE 1½"	SAE 1"
QX52/52	482	390			127				156			SAE 1¼"
QX62/32	480	388			112				120			G¾" 1) 2)
QX62/42	496,5	404,5	247	144	123	92	195	197	125	SAE 3"	SAE 1½"	SAE 1"
QX62/52	527	435			137				156			SAE 1¼"
QX62/62	546	454	252	149	149	92	195	197	197	SAE 3½"	SAE 1½"	SAE 1½"
QX82/42	601	484			140,5				125			SAE 1"
QX82/52	621,5	504,5	309	178,5	149,5	117	250		156	SAE 2"	SAE 2"	SAE 1¼"
QX82/62	640,5	523,5			161,5			197	SAE 1½"			
QX82/82	674,5	557,5			178,5			250	SAE 2"			

1) Threaded port to DIN 3852, Part 2.

2) Pressure port to SAE J518 code 61 / ISO 6162-1 can be supplied for pressure ranges 2+3.

F Double pumps QX.2/3

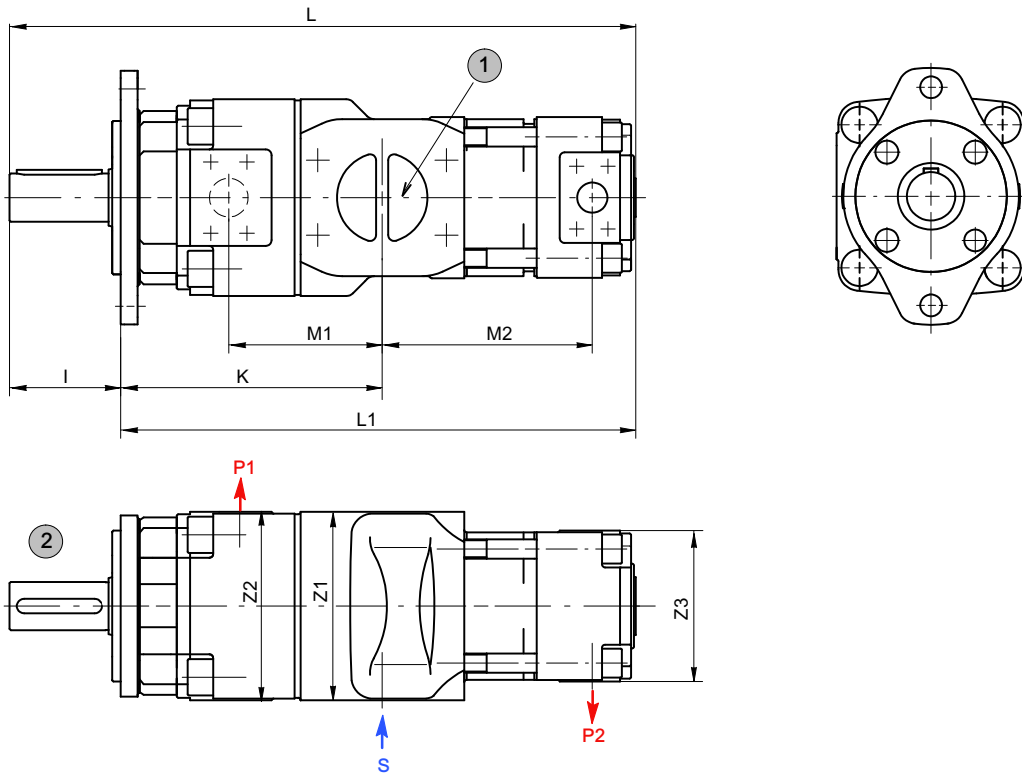

1 S = common suction port

2 shaft and mounting dimensions - see section 4

Type	L	L1	K	M1	M2	I	Z1	Z2	Z3	S	P1	P2
QX32/23	339	289	150,5	87	114	50	120		100	G1½" 1)	G¾" 1) 2)	G½" 1) 2)
QX42/23	386	318	174,5	103	119	68	125			SAE 2"	SAE 1"	G¾" 1) 2)
QX42/33	410	342			137							
QX52/23	452	360	209	119,5	126,5	92	156		100	SAE 2½"	SAE 1¼"	G½" 1) 2)
QX52/33	474,5	382,5			144,5			120	G¾" 1) 2)			
QX52/43	517	425			174			125	SAE 1"			
QX62/33	525	433	247	144	157	92	195	197	120	SAE 3"	SAE 1½"	G¾" 1) 2)
QX62/43	552,5	460,5			179				125			SAE 1"
QX62/53	597	505			207				156			SAE 1¼"
QX82/43	657	540	309	178,5	196,5	117	250		125	SAE 3½"	SAE 2"	SAE 1"
QX82/53	691,5	574,5			219,5			156	SAE 1¼"			
QX82/63	730,5	613,5			251,5			197	SAE 4"			SAE 1½"

1) Threaded port to DIN 3852, Part 2.

2) Pressure port to SAE J518 code 61 / ISO 6162-1 can be supplied for pressure ranges 2+3.

G Double pumps QX.3/1

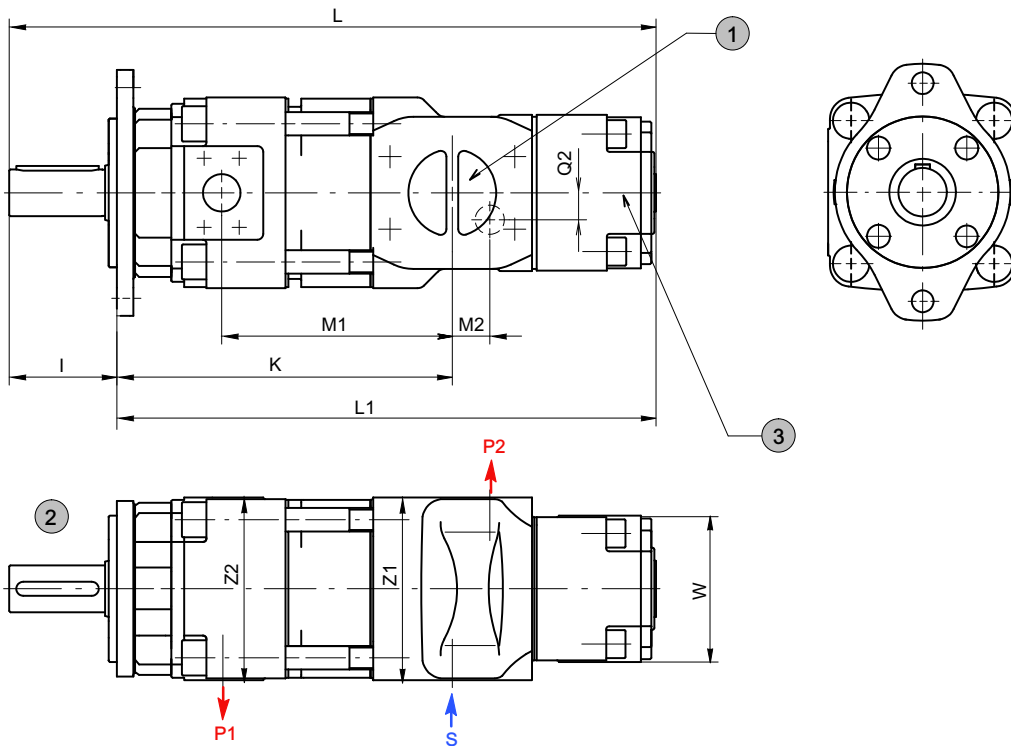

1	S = common suction port
2	shaft and mounting dimensions - see section 4

3	option 83 = depending on operating conditions, a second suction port may be required - see section 2.2.1 QX61=SAE 2"
---	--

Type	L	L1	K	M1	M2	Q2	I	Z1	Z2	W	S	P1	P2
QX33/21	366,5	316,5	195,5	132	30	-	50	120	120	80	G1½" 1)	G¾" 1) 2)	G½" 1) 2)
QX43/21	424,5	356,5	230,5	159	35	-	68	125	125		SAE 2"	SAE 1"	SAE 1"
QX43/31	439	371			33	15				92	156		
QX53/21	504,5	412,5	279	189,5	43	-	92	156	156			80	SAE 2½"
QX53/31	519	427			38,5	15				100	SAE 1"		
QX53/41	557	465	286,5	197	32	23	92	195	197			136	SAE 3"
QX63/31	589,5	497,5			337	234				47	14		
QX63/41	612,5	520,5	39	27			165	SAE 1"	SAE 1"				
QX63/51	649	557	342	239	40	28			117	250	250	136	SAE 3½"
QX83/41	742	625	424	293,5	50,5	25	117	250					
QX83/51	768,5	651,5			46,5	30			203	SAE 4"	SAE 2"	SAE 1¼"	
QX83/61	795,5	678,5			40,5	35	SAE 4"	SAE 2"				SAE 1½"	

1) Threaded port to DIN 3852, Part 2.

2) Pressure port to SAE J518 code 61 / ISO 6162-1 can be supplied for pressure ranges 2+3.

H Double pumps QX.3/2

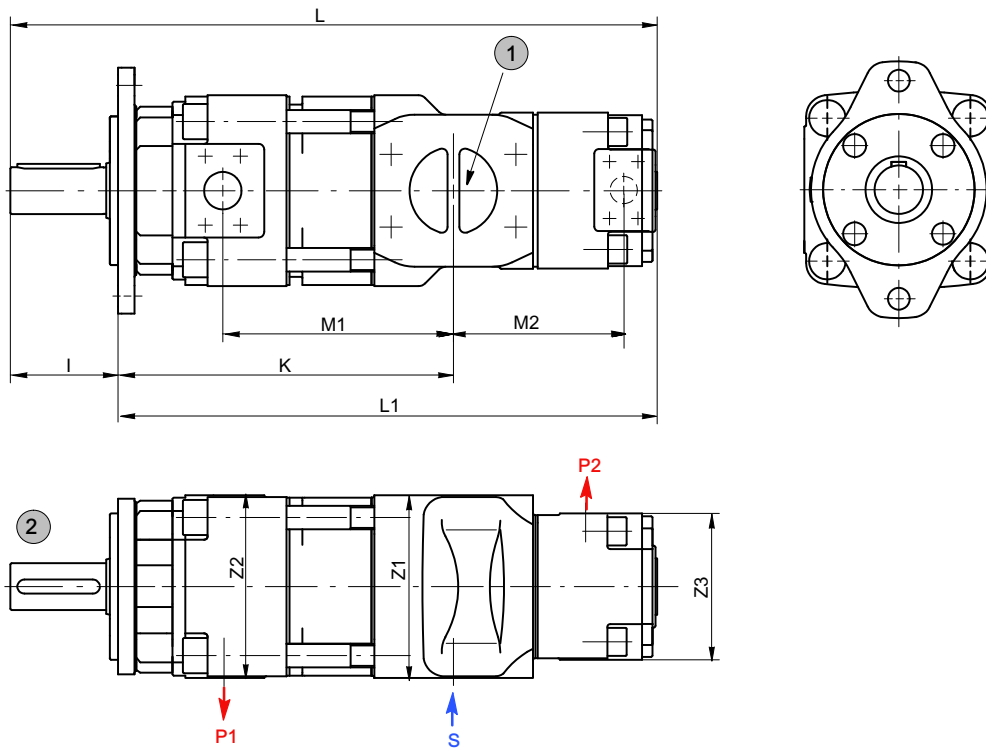

1 S = common suction port

2 shaft and mounting dimensions - see section 4

Type	L	L1	K	M1	M2	I	Z1	Z2	Z3	S	P1	P2
QX23/22	294	249	157,5	102	67	45	100		100	G1¼" ¹⁾	G½" ^(1) 2)	G½" ^(1) 2)
QX33/22	349	299	195,5	132	79	50	120		100	G1½" ⁽¹⁾	G¾" ^(1) 2)	G¾" ^(1) 2)
QX33/32	362	312			87			120				
QX43/22	407	339	230,5	159	84	68	125		100	SAE 2"	SAE 1"	G½" ^(1) 2)
QX43/32	420	352			92			120	G¾" ^(1) 2)			
QX43/42	451	383			110,5			125	SAE 1"			
QX53/22	487	395	279	189,5	91,5	92	156		100	SAE 2½"	SAE 1¼"	G½" ^(1) 2)
QX53/32	499,5	407,5			99,5			120	G¾" ^(1) 2)			
QX53/42	531	439	286,5	197	118	92	195	197	125	SAE 3"	SAE 1½"	SAE 1"
QX53/52	552	460			127				156			SAE 1¼"
QX63/32	571	479	337	234	112	92	195	197	120	SAE 3½"	SAE 1½"	G¾" ⁽¹⁾
QX63/42	586,5	494,5			123				125			SAE 1"
QX63/52	617	525	342	239	137	92	195	197	156	SAE 3½"	SAE 1½"	SAE 1¼"
QX63/62	636	544			149				197			SAE 1½"
QX83/42	716	599	424	293,5	140,5	117	250		125	SAE 3½"	SAE 2"	SAE 1"
QX83/52	736,5	619,5			149,5			156	SAE 1¼"			
QX83/62	756	639			161,5			197	SAE 1½"			
QX83/82	790	673			178,5			250	SAE 2"			

1) Threaded port to DIN 3852, Part 2.

2) Pressure port to SAE J518 code 61 / ISO 6162-1 can be supplied for pressure ranges 2+3.

I Double pumps QX.3/3

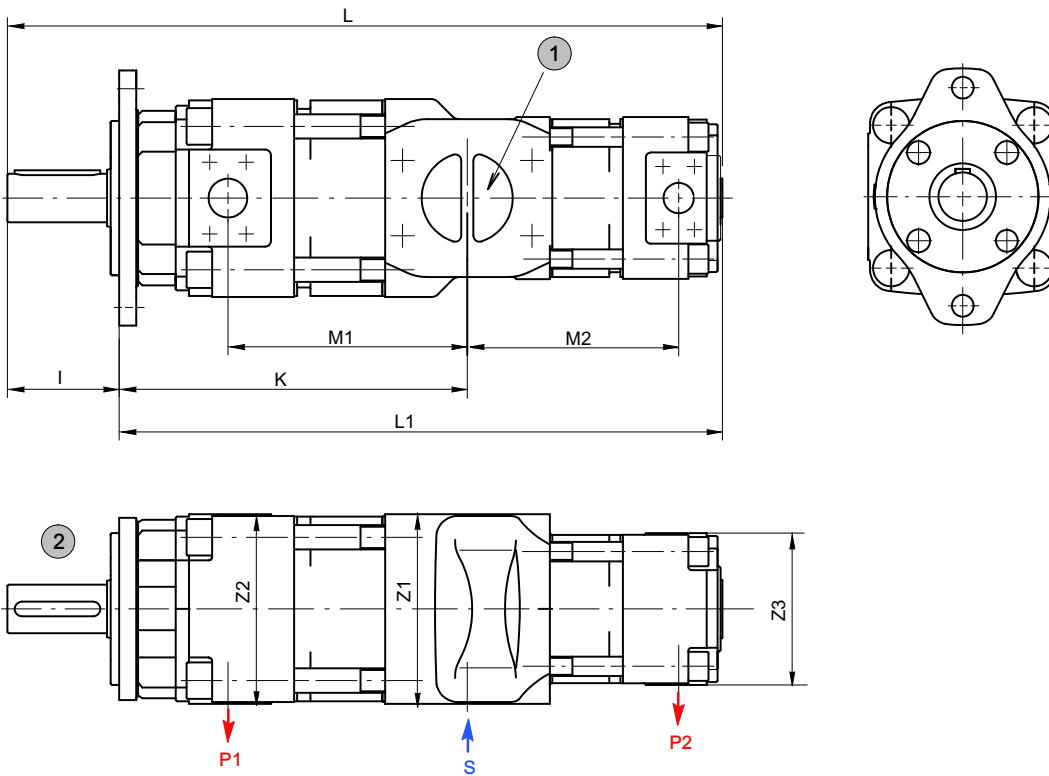

1 S = common suction port

2 shaft and mounting dimensions - see section 4

Type	L	L1	K	M1	M2	I	Z1	Z2	Z3	S	P1	P2
QX23/23	328,5	283,5	158	102	102	45	100		100	G1¼" 1) 2)	G½" 1) 2)	G½" 1) 2)
QX33/23	383,5	333,5	195,5	132	114	50	120		100	G1½" 1) 2)	G¾" 1) 2)	G¾" 1) 2)
QX33/33	406,5	356,5			132			120				
QX43/23	442	374	230,5	159	119	68	125		100	SAE 2"	SAE 1"	G½" 1) 2)
QX43/33	464,5	396,5			137			120	G¾" 1)			
QX43/43	507	439			166,5			125	SAE 1"			
QX53/23	522	430	279	190	126,5	92	156		100	SAE 2½"	SAE 1¼"	G½" 1) 2)
QX53/33	544,5	452,5			145			120	G¾" 1) 2)			
QX53/43	587	495	286,5	197	174	92	195	197	125	SAE 3"	SAE 1½"	SAE 1"
QX53/53	622	530			197				156			SAE 1¼"
QX63/33	615	523			337				234			157
QX63/43	642,5	550,5	342	239	179	92	195	197	125	SAE 3½"	SAE 1½"	SAE 1"
QX63/53	687	595			207				156			SAE 1¼"
QX63/63	727	635			239				197			SAE 1½"
QX83/43	772	655	424	293,5	196,5	117	250		125	SAE 4"	SAE 2"	SAE 1"
QX83/53	806,5	689,5			220			156	SAE 1¼"			
QX83/63	846	729			253,5			197	SAE 1½"			
QX83/83	904,5	787,5			293,5			250	SAE 2"			

1) Threaded port to DIN 3852, Part 2.

2) Pressure port to SAE J518 code 61 / ISO 6162-1 can be supplied for pressure ranges 2+3.

5.3 Ordering code for double pumps

		Q	X	6	3	-	0	8	0	/	3	1	-	0	2	0	R	*	*
Series	= QX																		
Frame size	= 2 / 3 / 4 / 5 / 6 / 8																		
Pressure range	= 1 / 2 / 3 / 4 ¹⁾																		
Displacement [cm ³ /rev]	= 5,1 - 495,4																		
	Frame size	= 2 / 3 / 4 / 5 / 6 / 8																	
	Pressure range	= 1 / 2 / 3 / 4 ¹⁾																	
	Displacement [cm ³ /rev]	= 5,1 - 495,4																	
Rotation (viewed from shaft end)	right (CW) = R (standard) left (CCW) = L																		
Option	see section 5.3.3																		

1) Pressure range 4 on request.

5.3.1 Ordering example:

Required: double pump

Pump 1

Displacement: 80 cm³/rev

Continuous pressure: 300 bar

Type: 63-080

for use with mineral oil

Ordering code: QX63-080/31-020R

Pump 2

Displacement: 20 cm³/rev

Continuous pressure: 160 bar

Type: 31-020

5.3.2 Standard configuration

- direction of rotation - right (CW)
- 2-hole mounting flange to ISO 3019/1 (SAE): sizes QX 3-6
- 2-hole mounting flange to ISO 3019/2 (metric): sizes QX 2+8
- Nitrile seals
- parallel shaft end to ISO/R775
- black priming, flange without priming

5.3.3 Options

- O = without priming
- 06 = external drain port in the pump rear cover
 - QX 2-5 = G¹/₄"
 - QX 6 = G³/₈"
 - QX 8 = G¹/₂"
- 09 = FPM (Viton) seals and without priming
- 12 = 2-hole mounting flange to ISO 3019/2 (metric): size QX 3-6
- 29 = for HFB and HFC fluids, frame sizes 2-5, without priming
- 66 = 4-hole mounting flange to ISO 3019/2 (metric)
- 83 = second suction port on:
 - QX51=SAE 1 1/4", QX61=SAE 2", QX81=SAE 2 1/2"
- 117 = pressure port to SAE J518 code 61 / ISO 6162-1 can be supplied for frame size 2+3 with pressure ranges 2+3

Further options on request.

6 Triple pumps

The following table shows the triple-pump combinations that can be supplied (other triple-pumps on request). The individual pumps 1, 2 and 3 must be specified in accordance with the main characteristics shown in section 2.

The largest pump of the combination is situated at the shaft end and is referred to as Pump 1. For equal frame sizes, the pump with the larger displacement is situated at the drive side. Pumps 2 and 3 have a common suction port.

IMPORTANT: Triple pumps with pressure range 4 on request.

6.1 Selection table

Frame size of pump 1

QX2.	QX3.	QX4.	QX5.	QX5.	QX6.	QX8.
QX21/21/21	QX31/21/21	QX41/21/21	QX51/22/23	QX52/52/31	QX61/31/33	QX81/42/23
QX21/21/22	QX31/21/22	QX41/21/23	QX51/23/23	QX52/52/42	QX61/41/21	QX82/42/43
QX21/21/23	QX31/21/23	QX41/22/22	QX52/23/23	QX52/52/43	QX61/41/42	QX82/51/53
QX21/22/22	QX31/22/22	QX41/23/23	QX53/22/22	QX52/52/52	QX61/42/23	QX83/51/53
QX21/22/23	QX31/22/23	QX42/22/22	QX51/31/33	QX52/52/53	QX61/42/43	QX81/61/61
QX21/23/23	QX31/23/22	QX43/22/22	QX51/33/33	QX52/53/31	QX61/43/43	QX81/62/63
QX22/22/22	QX31/23/23	QX43/23/22	QX51/41/23	QX52/53/53	QX62/41/22	QX81/63/33
QX22/22/23	QX32/22/22	QX43/23/23	QX51/41/42	QX53/53/23	QX62/42/42	QX82/61/61
QX23/23/23	QX32/22/23	QX41/31/33	QX51/41/43	QX53/53/33	QX62/43/43	QX82/62/62
	QX32/23/23	QX41/33/22	QX51/42/22		QX63/43/22	QX82/63/31
	QX33/21/22	QX41/33/33	QX51/42/43		QX61/52/53	QX83/61/61
	QX33/21/23	QX42/31/32	QX51/43/21		QX61/53/23	QX83/63/43
	QX33/23/23	QX42/32/32	QX51/43/22		QX61/53/31	QX83/63/61
	QX31/31/21	QX42/33/32	QX51/43/23		QX62/52/32	QX81/81/61
	QX31/31/22	QX43/31/31	QX51/43/43		QX62/52/52	QX81/81/81
	QX31/31/23	QX43/33/33	QX52/42/23		QX62/53/22	QX82/82/52
	QX31/31/31	QX41/41/33	QX52/42/42		QX62/53/23	QX82/82/62
	QX31/31/33	QX41/42/21	QX52/43/22		QX62/53/31	QX82/82/63
	QX31/32/22	QX41/42/23	QX52/43/23		QX62/53/33	QX83/83/53
	QX31/33/33	QX41/42/42	QX52/43/43		QX63/51/51	
	QX32/32/22	QX41/43/21	QX53/41/22		QX63/53/53	
	QX32/32/23	QX41/43/22	QX53/41/23		QX61/61/31	
	QX32/32/32	QX41/43/23	QX53/42/22		QX61/61/33	
	QX32/32/33	QX42/42/22	QX53/42/43		QX61/61/41	
	QX33/33/23	QX42/42/23	QX53/43/23		QX61/61/53	
	QX33/33/33	QX42/42/31	QX51/51/21*		QX61/62/42	
		QX42/42/32	QX51/51/32		QX61/62/63	
		QX42/42/33	QX51/51/33		QX61/63/32	
		QX42/42/42	QX51/52/32		QX61/63/33	
		QX42/42/43	QX51/52/33		QX61/63/41	
		QX43/43/43	QX51/52/42		QX61/63/42	
			QX51/52/43		QX62/62/33	
			QX51/53/22		QX62/62/43	
			QX51/53/23		QX62/62/53	
			QX51/53/31		QX62/62/62	
			QX51/53/33		QX62/62/63	
			QX51/53/41		QX62/63/63	
			QX51/53/43		QX63/63/32	
			QX51/53/52		QX63/63/43	
			QX52/52/23		QX63/63/53	
65	130	260	520	520	1050	2100

Max. permissible drive shaft torque [Nm]

* pump is used as the ordering example in section 6.2

6.2 Ordering code for triple pumps

Triple pumps can only be supplied after consulting Bucher Hydraulics GmbH.

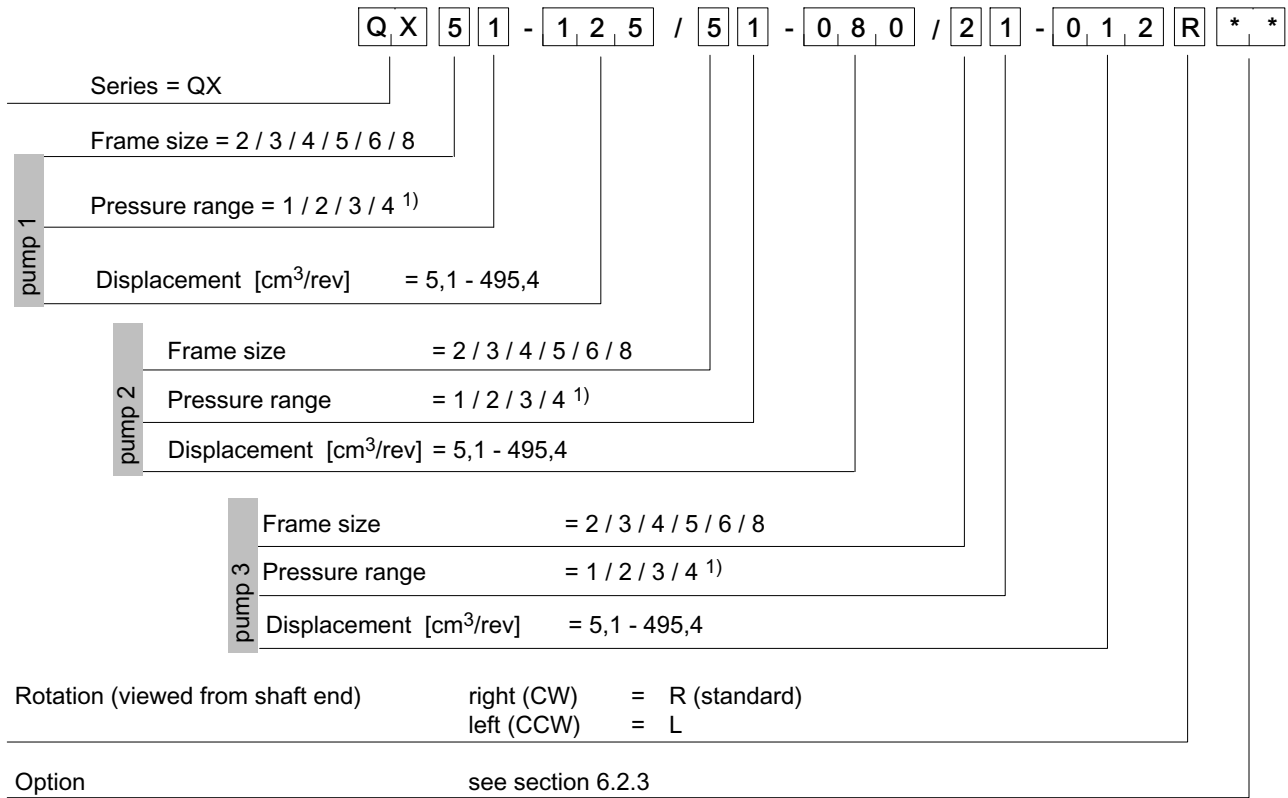

1) Pressure range 4 on request.

6.2.1 Ordering example:

Required: triple pump

Pump 1

Displacement: 125 cm³/rev

Continuous pressure: 80 bar

Type: 51-125

Pump 2

Displacement: 80 cm³/rev

Continuous pressure: 150 bar

Type: 51-080

Pump 3

Displacement: 12 cm³/rev

Continuous pressure: 125 bar

Type: 21-012

For use with mineral oil

Referring to the selection table in sect. 6.1, QX51/51/21 is an obtainable combination.

Ordering code: QX51-125/51-080/21-012R

6.2.2 Standard configuration

- direction of rotation - right (CW)
- 2-hole mounting flange to ISO 3019/1 (SAE): sizes QX 3-6
- 2-hole mounting flange to ISO 3019/2 (metric): sizes QX 2+8
- nitrile seals
- parallel shaft end to ISO/R775
- black priming, flange without priming

6.2.3 Options

- O = without priming
- 06 = external drain port in the pump rear cover
QX 2-5 = G¹/₄", QX 6 = G³/₈", QX 8 = G¹/₂"
- 09 = FPM (Viton) seals and without priming
- 12 = 2-hole mounting flange to ISO 3019/2 (metric): size QX 3-6
- 29 = for HFB and HFC fluids, frame sizes 2-5, without priming
- 66 = 4-hole mounting flange to ISO 3019/2 (metric)
- 83 = second suction port on:
QX51=SAE 1¹/₄", QX61=SAE 2", QX81=SAE 2¹/₂"
- 117 = pressure port to SAE J518 code 61 / ISO 6162-1 can be supplied for frame size 2+3 with pressure ranges 2+3

Further options on request.

7 Low-flow capability pump in combination with other QX-single pumps

7.1 Dimensions

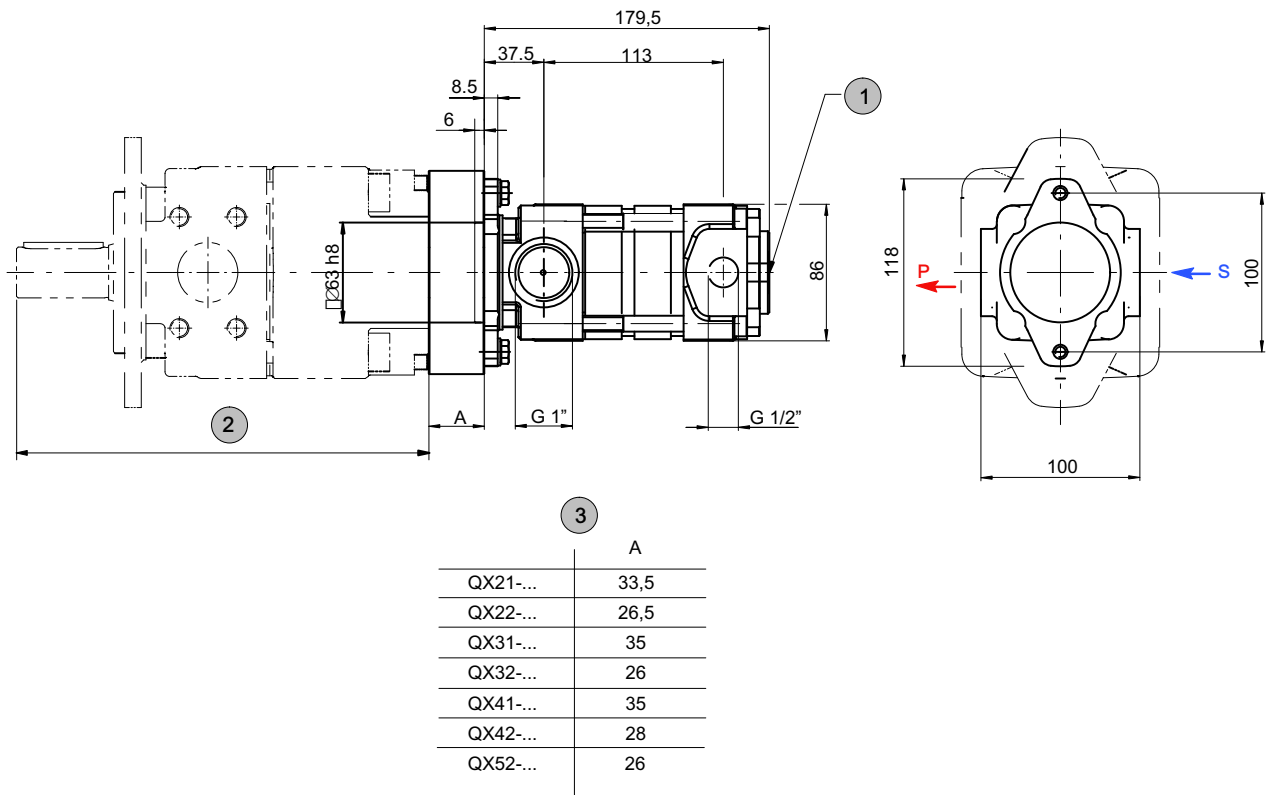

1	external drain port G 1/4"
2	dimensions see section 4

3	dimension A depends on the driving QX pump model (2)
---	--

7.2 Ordering code

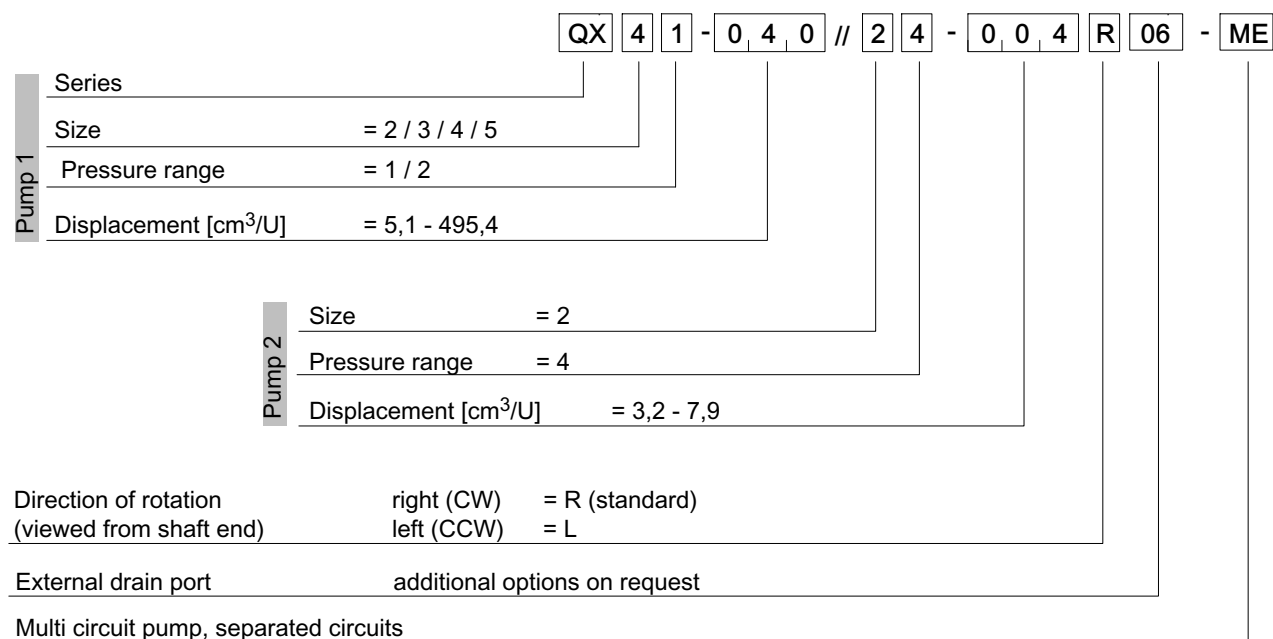

7.2.1 Ordering example:

Required: Double pump

Pump 1

Displacement: 40 cm³/rev
 Continuous pressure: 160 bar
 Type: 41 - 040

Pump 2

Displacement: 4 cm³/rev
 Continuous pressure: 250 bar
 Type: 24 - 004

For use with mineral oil:

Ordering code: QX41-040//24-004R06-ME

8 Fluid

QX pumps require fluid with a minimum cleanliness level of ISO 4406 code 20/18/15.

We recommend the use of fluids that contain anti-wear additives for mixed-friction operating conditions. Fluids without appropriate additives can reduce the service life of pumps and motors. The user is responsible for maintaining, and regularly checking, the fluid quality. Bucher Hydraulics recommends a load capacity of $\geq 30 \text{ N/mm}^2$ to Brügger DIN 51347-2.

9 Fluid cleanliness class

Cleanliness class (RK) onto ISO 4406

Code ISO 4406	Number of particles / 100 ml		
	$\geq 4 \mu\text{m}$	$\geq 6 \mu\text{m}$	$\geq 14 \mu\text{m}$
23/21/18	8000000	2000000	250000
22/20/18	4000000	1000000	250000
22/20/17	4000000	1000000	130000
22/20/16	4000000	1000000	64000
21/19/16	2000000	500000	64000
20/18/15	1000000	250000	32000
19/17/14	500000	130000	16000
18/16/13	250000	64000	8000
17/15/12	130000	32000	4000
16/14/12	64000	16000	4000
16/14/11	64000	16000	2000
15/13/10	32000	8000	1000
14/12/9	16000	4000	500
13/11/8	8000	2000	250

10 Operational reliability

To guarantee the reliable operation and a long service life of the pump, a maintenance schedule must be prepared for the power unit, machine or system. The maintenance schedule must make sure that the provided or permissible operating conditions of the pump are adhered to over the period of use.

In particular, compliance with the following operating parameters must be ensured:

- required oil cleanliness
- operating temperature range
- fluid level

Moreover, the pump and the system must be inspected at regular intervals for changes in the following parameters:

- Vibration
- Noise
- Differential temperature of pump – fluid in the tank
- Foaming in the tank
- Leak tightness

Changes in these parameters indicate wear of components (e.g. drive motor, coupling, pump, etc.). The cause must be immediately pinpointed and eliminated.

To provide high operational reliability of the pump in the machine or system, we recommend continuous, automatic checks of the above parameters and an automatic shut-down in the case of changes that exceed the usual fluctuations within the provided operating range.



Make sure that the plastic components of the coupling will be exchanged regularly (no later than 5 years). The manufacturer's instructions must be given priority.

11 Note

This catalogue is intended for users with specialist knowledge. The user must check the suitability of the equipment described here in order to ensure that all of the conditions necessary for the safety and proper functioning of the system are fulfilled. If you have any doubts or questions concerning the use of these pumps, please consult Bucher Hydraulics GmbH.

12 Accessories

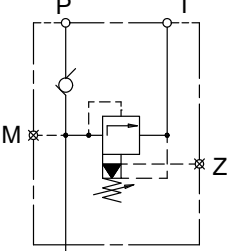
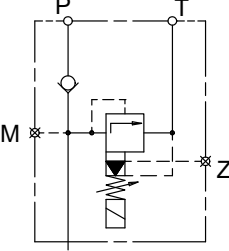
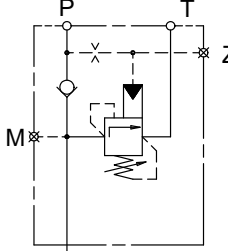
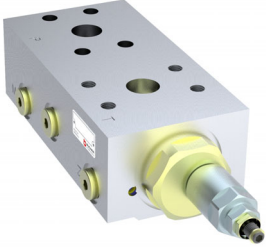
12.1 Bolt-on valves - SAE J518 code 61 / ISO 6162-1 pattern

Pressure relief valve A _G DF	Pressure relief valve solenoid control A _G DA	Accumulator charging valve AGSF
		
		
Technical data sheet 100-P-000123	Technical data sheet 100-P-000119	Technical data sheet 100-P-0000124

12.1.1 Examples for Bolt-on valves, mounted on QX Internal Gear Pumps

AGDF Bolt-on valve with threaded ports	ASDF+RF Bolt-on valves with pipe flanges SAE ¹⁾	Bolt-on valve with pipe flanges SAE + RVSAE ²⁾ ASDF+RF+RVSAE+DPSAE+ZPSAE
		

1) Pipe flange see section 12.2 and 12.3.

2) Please ask Bucher Hydraulics GmbH for check valves.

IMPORTANT: For detailed informations on Bolt-on valves see www.bucherhydraulics.com

12.2 Pipe flanges - high pressure type

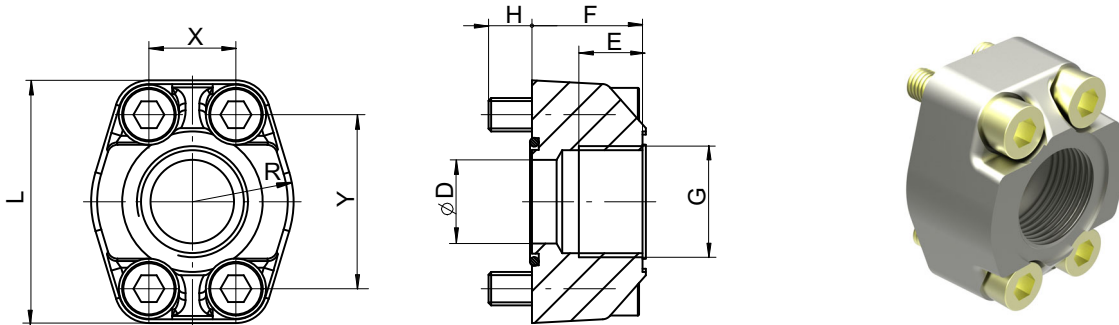

- Max. operating pressure 420 bar
- Flange size SAE J518 code 61 / ISO 6162-1

Threaded pipe flanges are spot-faced for DIN 2353 pipe fittings.

Material: ST37 / for FPM (Viton) seals, contact Bucher Hydraulics GmbH.

Ordering-number	Ordering code	Size	D \varnothing	E	F	H	L	R	X	Y	Viton seal 90 Shore A	Retaining screws DIN912-12.9 / [Nm]	
100037000	RF 01-R08	G $\frac{1}{2}$ "	12,5	16	27	13	54	23	17,5	38	20,24x2,62	M8x30	30
100037010	RF 02-R10	G $\frac{3}{4}$ "	20	18	30	12	65	26	22,2	47,6	26,65x2,62	M10x30	60
100037020	RF 03-R11	G1"	25	20	34	13	70	29	26,2	52,4	32,99x2,62	M10x35	60
100037030	RF 04-R12	G1 $\frac{1}{4}$ "	32	22	38	14	80	36	30,2	58,6	40,86x3,53	M10x40	60
100037040	RF 05-R13	G1 $\frac{1}{2}$ "	38	24	41	19	94	41	35,7	70	44,04x3,53	M12x45	120
100037050	RF 06-R14	G2"	50	26	45	20	102	48	42,9	77,8	59,92x3,53	M12x50	120
100055470*	RF 07-R16	G2 $\frac{1}{2}$ " *	63	30	50	18	114	57	50,8	89	72,62x3,53	M12x45	120

* at RF07 only to 210 bar be allowed

12.3 Pipe flanges - low pressure type

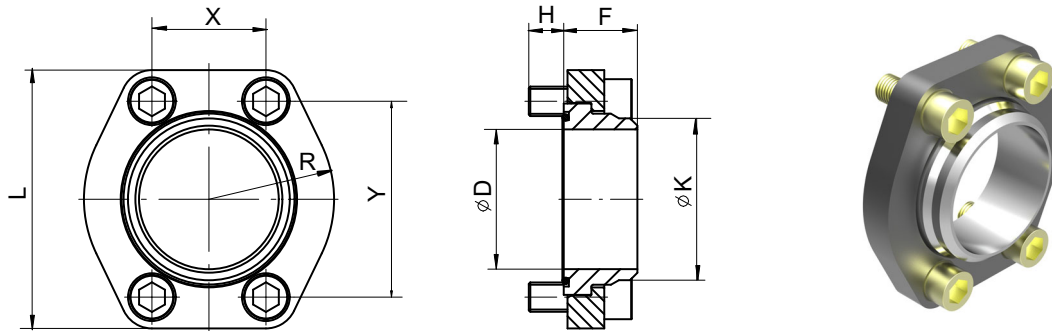

- Max. operating pressure 16 bar
- Flange size SAE J518 code 61 / ISO 6162-1.

Material: HST37 / for FPM (Viton) seals, contact Bucher Hydraulics GmbH.

Ordering number	Ordering code	SAE flange Size	D	K	F	H	L	R	X	Y	Viton seal 90 Shore 'A'	Retaining screws DIN 912-8.8 Torque [Nm]		pipe ¹⁾ O/dia. ap- prox.
												M	Torque [Nm]	
100062450	RN 07-S	2½"	63	75	35	14	120	57	51	89	69,44x3,53	M12 x 30	70	75
100063880	RN 08-S	3"	76	88			140,5	68	62	106,5	85,32x3,53	M16 x 40	180	88
100063890	RN 09-S	3½"	89	100	40	19	158,5	73	70	120,3	98,02x3,53	M16 x 40	180	100
100063900	RN 10-S	4"	103	115			168	79	78	130	110,72x3,53	M16 x 40	180	115

1) We recommend the use of seamless precision steel tube to DIN 2391 with wallthick. max 6 mm.

info.kl@bucherhydraulics.com

www.bucherhydraulics.com

© 2019 by Bucher Hydraulics GmbH, D-79771 Klettgau

All rights reserved.

Data is provided for the purpose of product description only, and must not be construed as warranted characteristics in the legal sense. The information does not relieve users from the duty of conducting their own evaluations and tests. Because the products are subject to continual improvement, we reserve the right to amend the product specifications contained in this catalogue.

Classification: 410.100.000